

## >B< Press XL Installation Process

To install >B< Press XL, a press tool, actuator and compatible sized press ring to fit each size fitting is required.

When force is exerted through the press tool a permanent joint is made and the fitting cannot be disassembled or reused.

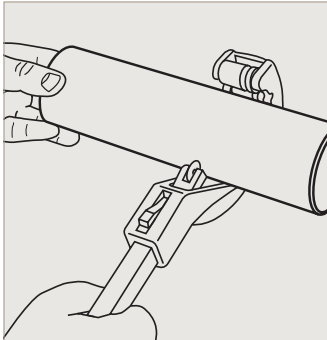

1. Cut tube to length

- We recommend you use a rotary tube cutter. It is important to ensure that the tube is cut completely square.
- Tube ends should be clean and free from scratches no less than the socket length.

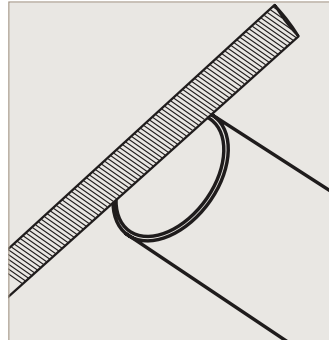

2. Deburr

- Make sure that the internal and external tube end is free from burrs or sharp edges by using a half round file or deburring tool.
- Then wipe the tube end clean to avoid damaging the seal on tube insertion.

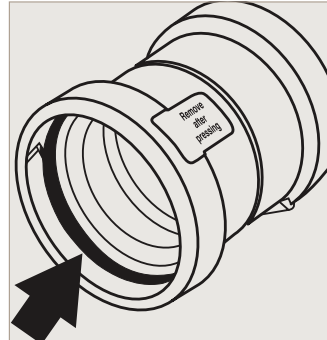

3. Check the fittings

- Before inserting the tube, check seal for correct placement, damage or any ingress of debris.
- To prevent this occurring we recommend the fittings are retained in packaging up to the point of use.

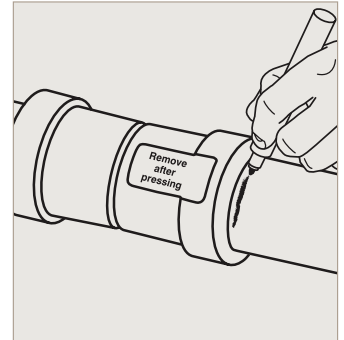

4. Mark the insertion depth

- The tube must be fully inserted into the fitting until it reaches the tube stop in order to make a perfect joint.
- Marking insertion depth will ensure that any tube movement is detected, which is especially important if the joints are to be pressed at a later time.
- The depth marking must be visible on the pressed fitting.

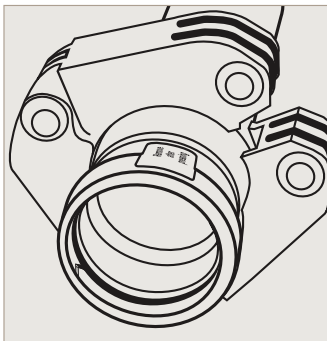

5. Fit the pressing ring

- Using the appropriate size pressing ring, open the pressing ring, locate on the fitting bead and close the pressing ring.

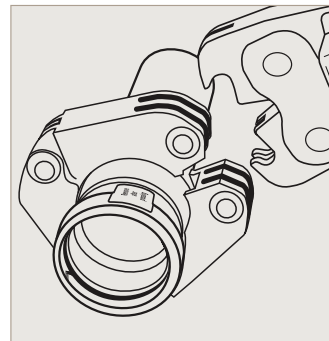

6. Engage the actuator and check insertion depth

- With the actuator fitted in the press tool open the actuator and locate the actuator onto the aperture of the pressing ring.
- Check for any tube movement prior to pressing.

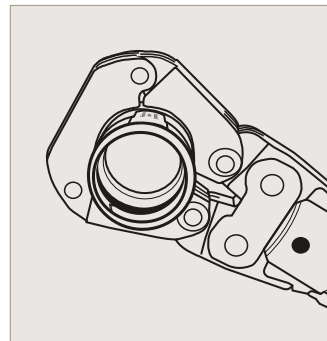

7. Press the joint

- Depress and hold the trigger of the tool until the press cycle of the tool is automatically completed. Keep hands clear of the press actuator and press ring until the cycle is completed.
- Do not repress the fitting.

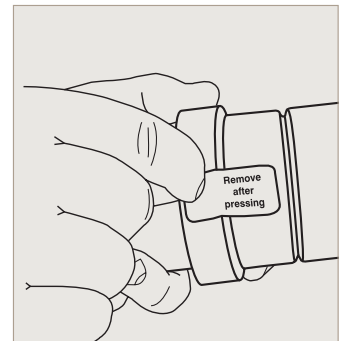

8. Joint completion

- Remove the actuator from the press ring, remove the press ring from the tube and remove the label to indicate the joint is pressed and complete.

For the full tool compatibility chart please refer to [www.conexbanninger.com](http://www.conexbanninger.com) or the technical brochure.

### Important

It is important to keep the fitting free of any dust or dirt, and to ensure the seal stays lubricated and protected from damage. Select the correct size of tube and fitting for the job. Ensure that both are clean and free from damage and imperfections. When using a press tool always wear ear and eye protection.