

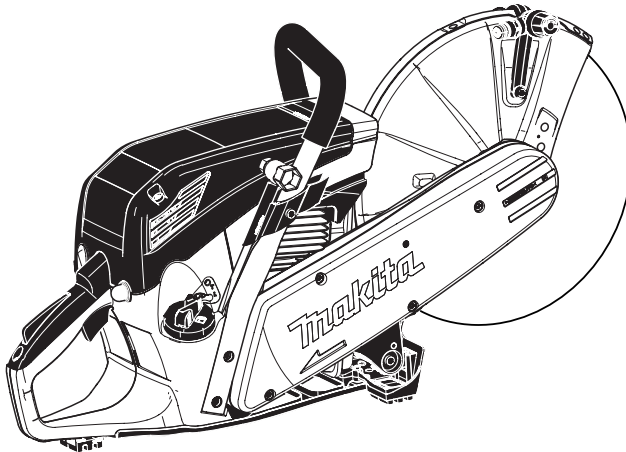

Instruction Manual

Original Instruction Manual



EK6100
EK6101



Important:

Read this instruction manual carefully before putting the Power Cut into operation and strictly observe the safety regulations!

Keep this instruction manual!

Thank you for purchasing a MAKITA product!

Congratulations on choosing a MAKITA Power Cut cutoff saw! Like our chain saws, the MAKITA Power Cuts feature specially designed high-performance engines with outstanding power-to-weight ratios, for heavy-duty yet lightweight tools.

Other advantages of the MAKITA Power Cuts:

- Sturdy construction and high reliability.
- Maintenance-free electronic ignition, hermetically sealed to protect against dust and moisture.
- Vibration damping with the MAKITA 2-mass system (D2M) for tireless working even when guiding the Power Cut by hand.
- Multilevel air filter system with turbo-cyclone filter for dependable function even under very dusty conditions.
- The Featherlight-Start system lets you start the cutter effortlessly with a spring-loaded starting assist.
- Extensive range of resin-bonded and diamond grit cutting discs.

The following industrial property rights apply:

DE 202010000143 U1, DE 202011050393 U1, DE 202011050396 U1, DE 202011050394 U1, DE 202010004275 U1, DE 202009010557 U1, DE 202009006860 U1, DE 202008003781 U1.

We want you to be satisfied with your MAKITA product.

In order to guarantee the optimal function and performance of your Power Cut and to ensure your personal safety we would request you to perform the following:

Read this instruction manual carefully before putting the Power Cut into operation for the first time, and strictly observe the safety regulations! Failure to observe these precautions can lead to severe injury or death!



EU Conformity Declaration

The undersigned, Tomoyasu Kato, as authorized by MAKITA Corporation, declare that the MAKITA machines,

Type: 315

Power Cut EK6100, EK6101

manufactured by MAKITA Corporation, 3-11-8 Sumiyoshi-Cho, Anjo, Aichi, 446-8502 Japan, conforms to the basic safety and health requirements of the applicable EU Directives:

EU Machinery Directive 2006/42/EG, EU EMC Directive 2004/108/EG, Outdoor Noise Directive 2000/14/EG.

The most important standards applied to properly meet the requirements of the above EU Directive were: EN 19432, CISPR 12, EN ISO 14982, DIN EN 61000-4.

The conformity assessment procedure 2000/14/EG was performed per Annex V. The measured noise level (L_{wa}) is 114 dB(A). The guaranteed noise level (L_d) is 115 dB(A).

The technical documentation is on file at MAKITA International Europe Ltd., Michigan Drive, Tongwell, Milton Keynes, Bucks, MK15 8JD, England.

Anjo, 20.8.2012 for MAKITA Corporation

Tomoyasu Kato
Managing Director

Table of contents

Page

Packing	2
Delivery inventory	3
Symbols	3
SAFETY PRECAUTIONS	
Intended use	4
General precautions	4
Protective equipment	4-5
Fuels / Refuelling	5
Putting into operation	5
Cutting discs	6
Kickback and lock-in	7
Working behavior / Method of working	7
Always observe the following when using synthetic resin cutting discs	8
Cutting metal	8
Cutting masonry and concrete	8-9
Transport and storage	9
Maintenance	10
First aid	10
Disposal and environmental protection	10

Technical data	11
Denomination of components	12

PUTTING INTO OPERATION

Mounting the cutting disc	13
Fuels / Refuelling	14-15
Starting the engine	16
Cold-starting	16
Warm-starting	16
Stop engine	16
Adjusting the carburetor	17

MAINTENANCE

Changing the V-belt	18
Cleaning the protection hood	19
Cleaning / changing the air filter	19
Replacing the spark plug	20
Checking the ignition spark	20
Replacing the suction head	20
Replacing the starter cable	21
Replacing the return spring	22
Replacing the start spring	22
Instructions for periodic maintenance	23

Service, spare parts and guarantee	23-24
Troubleshooting	25

SPECIAL ACCESSORIES

Diamond cutting discs, water tank	25
Extract from spare parts list	26-27

Packing

Your MAKITA Power Cut is packed in a cardboard box to prevent shipping damage.

Cardboard is a basic raw material and is consequently reusable or suitable for recycling (waste paper recycling).



Delivery inventory

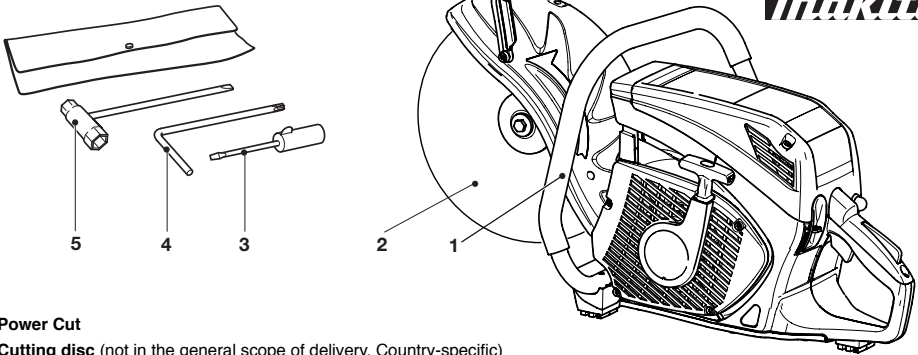

1. Power Cut
2. Cutting disc (not in the general scope of delivery. Country-specific)
3. Screwdriver (for carburetor adjustment)
4. Offset screwdriver
5. Universal wrench 13/19
6. Instruction manual (not shown)

In case one of the parts listed should not be included in the delivery inventory, please consult your sales agent.

Symbols

You will notice the following symbols on the Power Cut and in the Instruction Manual:

	Read instruction manual and follow the warning- and safety precautions!		Never use circular saw blades!
	Particular care and caution!		Never use damaged cutting discs!
	Forbidden!		Combination switch Choke, On/Stop
	Wear helmet and eye, respiratory and hearing protection!		Safety position
	Wear protective gloves!		Start engine
	Wear respiratory protection!		Stop engine!
	Hazardous dust and/or gas emission!		Warning! Kickback!
	Fire hazard from flying sparks!		Fuel and oil mixture
	No smoking!		First aid
	No open fire!		Recycling
	Direction of cutting wheel rotation		Max cutting speed
	Warning: the max. peripheral speed of the cutting disc is 80 m/s!		CE - Marking
	Cutting disc dimensions		

SAFETY PRECAUTIONS

Note: The illustrations in the safety precautions are not identical with the product!

Intended use

Power Cut

Use the Power Cut cutoff saw outdoors only, for trimming and cutting suitable materials, using cutting discs rated for this machine.

Improper use:

Never use the cutoff saw cutting discs for grinding or sanding (using the side of the cutting disc to remove material). The disc can break! Never use the Power Cut with saw blades, cutter blades, brushes etc.

Unauthorised users:

Persons unfamiliar with the Instruction Manual, children, young people, and persons under the influence of alcohol, drugs or medications must not use the Power Cut.

General precautions

- **The operator MUST read this instruction manual to ensure safe operation (even if you already have experience in using cutoff saws).** It is important to be familiar with the operation of this particular cutoff saw. Users insufficiently informed will endanger themselves as well as others due to improper handling.
- Let only persons who have experience in using cutoff saws work with this unit. When letting another person use the Power Cut, this instruction manual must be provided along with it.
- First-time operators should ask a specialist to instruct them in working with gasoline-powered cutoff saws.
- Children and persons under 18 years of age must not be allowed to use this Power Cut. Persons over the age of 16 years may, however, use the Power Cut for the purpose of being trained as long as they are under the supervision of a qualified trainer.
- Working with the Power Cut requires high concentration.
- Operate the Power Cut only if you are in good physical condition. If you are tired, your attention will be reduced. Be especially careful at the end of a working day. Perform all work calmly and carefully. The user has to accept liability for others.
- Never work while under the influence of alcohol, drugs, medication or other substances which may impair vision, dexterity or judgement.
- A fire extinguisher must be available in the immediate vicinity when working in easily inflammable vegetation or when it has not rained for a long time (danger of fire).
- Asbestos and other materials that can release toxins may be cut only with the necessary safety precautions and after notification of the proper authorities and under their supervision or that of a person appointed by them.
- The use of dust-reduction devices is urgently recommended (see Accessories, pressure water tank, water tank).

Protective equipment

- **In order to avoid head, eye, hand or foot injuries as well as to protect your hearing the following protective equipment must be used during operation of the Power Cut:**
- The kind of clothing should be appropriate, i. e. it should be tight-fitting but not be a hindrance. Clothing in which grains of material can accumulate (trousers with cuffs, jackets and trousers with wide-open pockets, etc.) must not be worn, particularly when cutting metal.
- Do not wear any jewellery or clothing that can get caught or distract from the operation of the Power Cut.
- It is necessary to wear a protective helmet whenever working with the Power Cut. The **protective helmet (A)** is to be checked in regular intervals for damage and is to be replaced after 5 years at the latest. Use only approved protective helmets.

- The helmet **visor (B)** protects the face from dust and material grains. In order to prevent injuries to eyes and face, always wear **protective goggles (C)** or visor when using the Power Cut.
- To prevent hearing damage, always wear suitable personal **hearing protection**. (ear muffs (D), ear plugs, etc.) Octave brand analysis upon request.
- When dry-cutting dust-producing materials such as stone or concrete, always wear approved **respiratory protection (E)**.
- **Work gloves (F)** of tough leather are part of the required work kit of the Power Cut and must **always** be worn when working with the Power Cut.

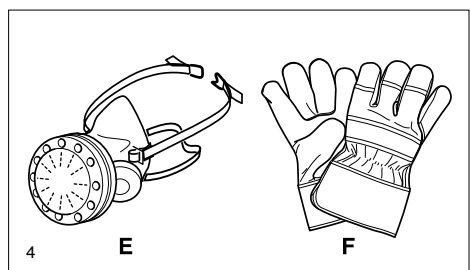
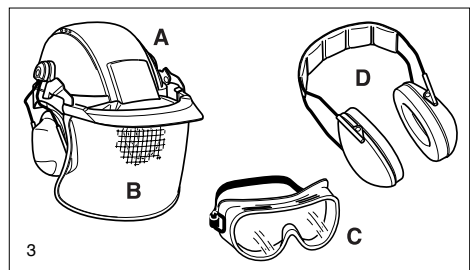
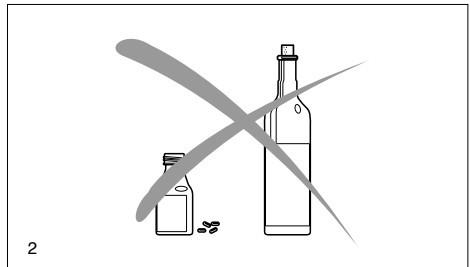
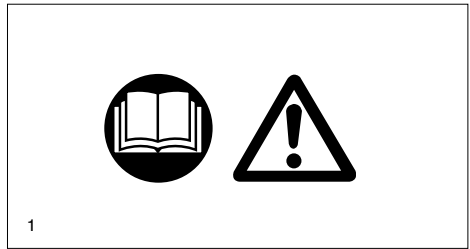

- Always wear **safety shoes or boots** (G) with steel toes, non-skid soles, and leg protectors when working with the Power Cut. Safety shoes equipped with a protective layer provide protection against cuts and ensure a secure footing.
- Always wear a **work suit** (H) of tough material with sufficient flame-retardant qualities whenever working with the cutoff saw.

Fuels / Refuelling

- Go to a safe, level place before refuelling. **Never refuel while on scaffolding, on heaps of material, or in similar places!**
- Switch off the engine before refuelling the Power Cut.
- Do not smoke or work near open fires (6).
- Let the engine cool down before refuelling.
- Fuels can contain substances similar to solvents. Eyes and skin should not come in contact with mineral oil products. Always wear protective gloves when refuelling (not the regular work gloves!). Frequently clean and change protective clothes. Do not breathe in fuel vapors. Inhalation of fuel vapours can be hazardous to your health.
- Do not spill fuel. If a spill occurs, clean off the Power Cut immediately. Fuel should not come in contact with clothes. If your clothes have come in contact with fuel, change them at once.
- Ensure that no fuel oozes into the soil (environmental protection). Use an appropriate base.
- Refuelling is not allowed in closed rooms. Fuel vapors will accumulate near the floor (explosion hazard).
- Ensure to firmly tighten the screw cap of the fuel tank.
- Before starting the engine, move to a location at least 3 meters (approx. 3 1/4 yards) from where you fuelled the Power Cut (7), but not within the extended swing range of the cutting disc (direction of sparks).
- Fuel cannot be stored for an unlimited period of time. Buy only as much as will be consumed in the near future.
- When making up the gasoline/oil mixture, always put the oil in the mixing container first, and then the gasoline.
- Use only approved and marked containers for the transport and storage of fuel.
- **Keep fuel away from children!**

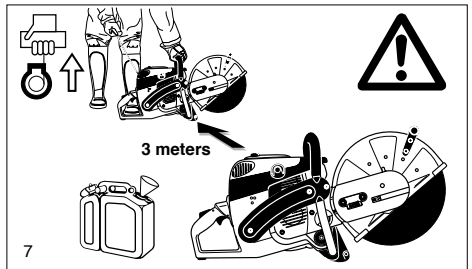
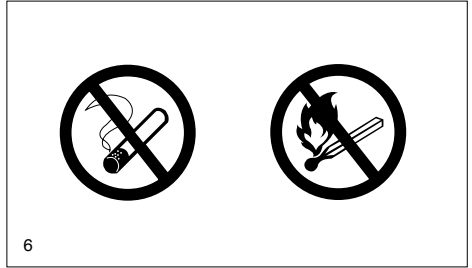
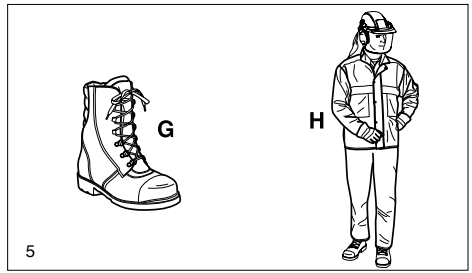

Putting into operation

- **Do not work on your own. There must be someone around in case of an emergency (within shouting distance).**
- Observe all anti-noise regulations when working in residential areas.
- **Never use the Power Cut near inflammable materials or explosive gases! The Power Cut can create sparks leading to fire or explosion!**
- Make sure that all persons within 30 meters (33 yards), such as other workers, are wearing protective gear (see "Protective Equipment") (8). Children and other unauthorized persons must remain more than 30 meters away from the working area. Keep an eye out for animals as well (9).
- **Before starting work the Power Cut must be checked for perfect function and operating safety according to the prescriptions.** In particular, make sure that the cutting wheel is in good condition (replace immediately if torn, damaged or bent), the cutting wheel is properly mounted, the protective hood is locked in place, the hand guard is properly mounted, the throttle moves easily and the half-throttle lock button functions properly, the grips are clean and dry, and the combination switch functions properly (Start/Stop (I/O) switch, choke).
- Start the Power Cut only after complete assembly and inspection. Never use the Power Cut when it is not completely assembled.

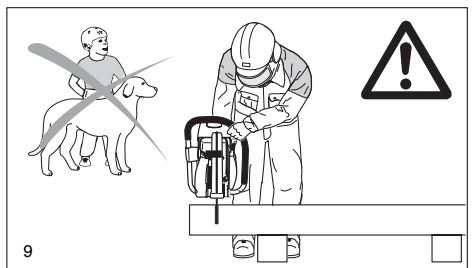
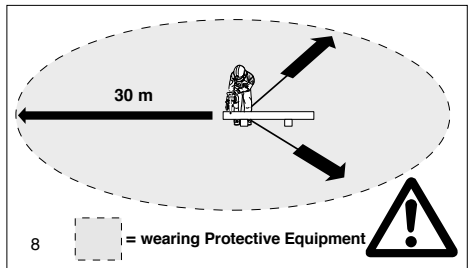

Cutoff discs

- **The protection hood must always be on! Change discs only with the engine off!**
- There are two basic types of cutoff discs:
 - For metal (hot cutting)
 - For masonry (cold cutting)

NOTE:

When using diamond cutoff discs, always make sure to observe the "direction of rotation" markings. Diamond discs should only be used for cutting masonry/brick/ concrete etc.

- Cutoff discs are intended only for radial loading, i.e. for cutting. Do not grind with the sides of the cutting disc! This will break the disc (10)!

Caution!

Never change direction (turning radius less than 5 meters / 5 1/2 yards), exert lateral (sideways) pressure, or tip the Power Cut during cutting (11)!

- Use a cutting disc only for cutting the materials it is intended for. The proper type of disc must be used, for either metals or masonry.
- The arbor hole of the cutting disc must be an exact fit with the arbor or shaft. If the arbor hole is larger, it must be fitted with an adapter ring (available as an accessory).
- The cutting disc must be rated for freehand cutting at up to 4370 rpm or 80 m/sec for 350 mm discs, or up to 5100 rpm or 80 m/s for 300 mm discs. Use only cutting discs that comply with EN 12413, EN 13236.
- The disc must be free of defects (12). Do not use defective cutting discs.

Always tighten the cutting disc mounting bolt to a torque of 30 Nm. Otherwise, the cutting disc can twist.

- Before starting the cutting disc, make sure you have a steady footing.
- Put the Power Cut into operation only as described in this instruction manual (13). Always place your left foot in the rear handle and grasp the other handle firmly (with thumb and fingers). Other starting methods are not allowed.
- When starting the Power Cut it must be well supported and securely held. The cutting disc must not be touching anything.
- If the cutting disc is new, test it by running it at least 60 seconds at top speed. When doing this, make sure that no persons or body parts are in the extended swing range of the disc, in case it is defective and flies apart.
- **When working with the Power Cut always hold it with both hands.** Take the back handle with the right hand and the tubular handle with the left hand. Hold the handles tightly with your thumbs facing your fingers.
- **CAUTION: When you release the throttle lever the disc will keep spinning for a short period of time (free-wheeling effect).**
- Continuously ensure that you have a safe footing.
- Hold the Power Cut such that you will not breathe in the exhaust gas. Do not work in closed rooms or in deep holes or ditches (danger of poisoning by fumes).
- **Switch off the Power Cut immediately if you observe any changes in its operating behavior.**
- Switch off engine before refuelling, changing the cutoff disc, work breaks, transporting or moving the Power Cut, taking it out of operation, or dealing with malfunctions. Before any maintenance work, move the combination switch to the lock symbol (14).
- Turn off the engine immediately and check the disc if you hear or feel any change in cutting behaviour.
- Turn off the Power Cut when taking a break or stopping work (14). Place the unit in such a way that the disc is not touching anything and cannot endanger anyone.
- Do not put the overheated Power Cut in dry grass or on any inflammable objects. The muffler is very hot (danger of fire).
- **IMPORTANT:** After wet cutting, first turn off the water feed and then let the disc run at least 30 seconds, to fling off the remaining water and prevent corrosion.

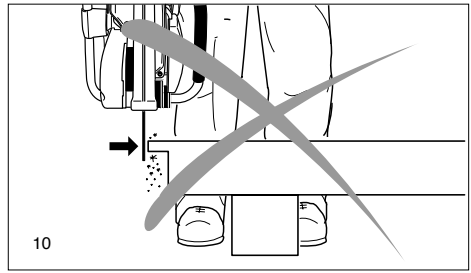

10

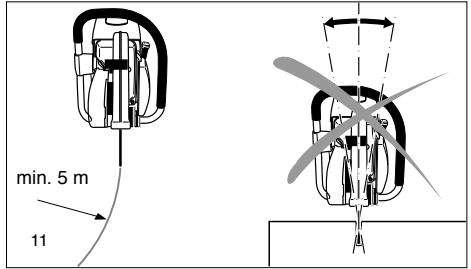

11

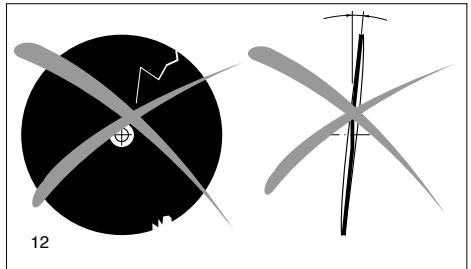

12

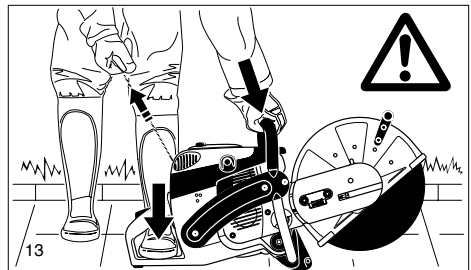

13

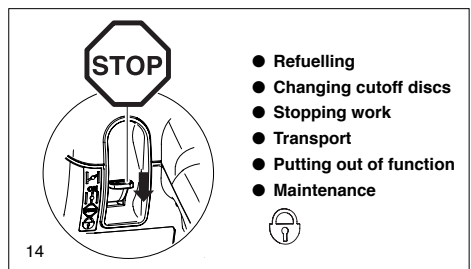

14

Kickback and lock-in

- When working with the Power Cut there is a danger of kickback and lock-in.
- Kickback occurs when the top of the cutting disc is used for cutting (15).
- This causes the Power Cut to be thrown back toward the user with great force and out of control. **Risk of injury!**

To prevent kickback, observe the following:

- Never cut with the section of the cutting disc shown in figure 15.
- **Be especially careful when reinserting the disc into cuts that have already been started!**
- Lock-in occurs when the cut narrows (crack, or workpiece under stress).
- This causes the Power Cut to suddenly jump forward, out of control and with great force. **Risk of injury!**

To prevent lock-in, observe the following:

- When reinserting the disc into previous cuts, have the Power Cut running at top speed. Always cut at top speed.
- Always support the workpiece so that the cut is under tension (16), so that the cut does not press together and jam the cutting disc as it proceeds through the material.
- When starting a cut, apply the disc to the workpiece with care. Do not just shove it into the material.
- Never cut more than one piece at a time! When cutting, make sure that no other workpiece comes into contact.

Working behavior / Method of working

- Before starting work, check the work area for any hazards (electrical wires, inflammable substances). Clearly mark the work area (for example with warning signs or by cordoning off the area).
- When working with the Power Cut hold it firmly by the front and rear handles. Never leave the Power Cut unattended!
- Use the Power Cut at high speed as far as possible (see "Technical Data").
- Only use the Power Cut during good light and visibility periods. Be aware of slippery or wet areas, and of ice and snow (risk of slipping).
- Never work on unstable surfaces. Make sure that there are no obstacles in the working area, risk of stumbling. Always ensure that you have a safe footing.
- Never cut above your shoulder height (17).
- Never stand on a ladder to cut (17).
- Never use the Power Cut while standing on scaffolding.
- Do not lean over too far when working. When putting down and picking up the Power Cut, do not bend over from the waist, but instead bend in the knees. Save your back!
- Guide the Power Cut in such a way that no part of your body is within the extended swing range of the disc (18).
- Use cutting discs only for the materials for which they are designed!
- Use cutting discs only for the materials for which they are designed. Do not use the Power Cut to lift up and shovel away pieces of material and other objects.

Important! Before cutting, remove all foreign objects, such as rocks, gravel, nails etc. from the cutting area. Otherwise, such objects can be flung away by the disc with great speed. **Injury hazard!**

- When cutting workpieces down to length use a firm support. If necessary, secure the workpiece from slipping, but do not steady it with your foot or allow another person to hold it.
- When cutting round items, always secure them against rotation.

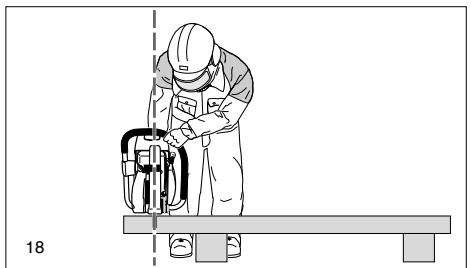
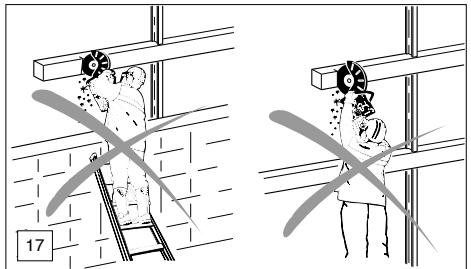
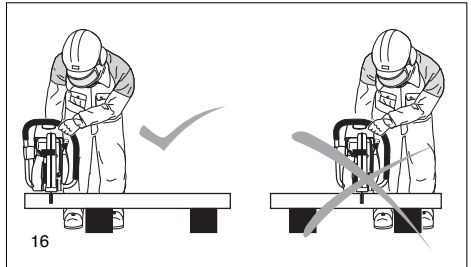

When using synthetic resin cutting discs, always observe the following:

CAUTION:

- Synthetic resin cutting discs can absorb moisture. This moisture can cause the disc to become unbalanced at high speed. This imbalance can cause the disc to break.
- Do not cool resin cutting discs with water or other fluids.
- Do not expose resin cutting discs to high humidity or rain!

Do not use resin cutting discs past their use-by date (expiration date)! The date (quarter and year) is stamped on the disc's arbor ring.

EXAMPLE: 04 / 2013

This cutting disc can be used through the end of the fourth quarter of 2013, if properly stored and correctly used.

Cutting metals

IMPORTANT!

Always wear approved respiratory protection!

Materials that can release toxic substances may be cut only after notifying the proper authorities and under their supervision or that of a person appointed by them.

CAUTION!

The rapid rotation of the cutting disc heats metal and melts it at the point of contact. Swing the guard as far down as possible (19) in order to direct the stream of sparks forward, away from the operator (fire hazard).

- Determine the cut line, mark the cut and apply the disc to the material at moderate speed, to cut a guide groove before going to top speed and applying more pressure to the Power Cut.
- Keep the disc straight and vertical. Do not tip it, as this can break it.
- The best way to get a good, clean cut is to pull or move the Power Cut back and forth. Do not simply press the disc into the material.
- Thick round stock is best cut in stages (20).
- Thin tubing and pipes can be cut with a simple downward cut.
- Cut large-diameter pipes as for round stock. To prevent tipping and for better control, do not let the disc sink too deeply into the material. Instead, always cut shallow around the whole piece.
- Worn discs have a smaller diameter than new discs, so that at the same engine speed they have a lower effective circumferential speed and therefore do not cut as well.
- Cut I-beams and L-bars in steps; see Figure 21.
- Cut bands and plates like pipes: along the wide side with a long cut.
- When cutting material under stress (supported material or material in structures), always make a notch in the thrust (pressure) side, and then cut from the tension side, so that the disc does not lock in. **Secure cutoff material from falling!**

CAUTION!

If there is a chance that the material is under stress, be prepared for it to kick back. Make sure you can get out of the way if you have to!

Be particularly careful in scrap-metal yards, junkyards, at accident sites, and with haphazard piles of material. Precariously balanced pieces or pieces under stress can act in unpredictable ways, and may slide, jump out, or burst. Secure cutoff material from falling! Always exercise extreme caution and use only equipment that is in perfect working order.

Observe the accident-prevention rules and regulations of your employer and/or insurance organization.

Cutting masonry and concrete

IMPORTANT!

Always wear approved respiratory protection!

Asbestos and other materials that can release toxic substances may be cut only after notifying the proper authorities and under their supervision or that of a person appointed by them. When cutting prestressed and reinforced concrete piles, follow the instructions and standards of the responsible authorities or the builder of the structural member. Reinforcement rods must be cut in the prescribed sequence and in accordance with applicable safety regulations.

NOTE:

Mortar, stone, and concrete develop large quantities of dust during cutting. To increase the lifetime of the cutting disc (by cooling), to improve visibility, and to avoid excessive dust creation, we strongly recommend wet cutting instead of dry cutting.

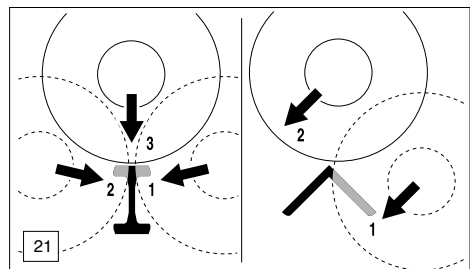
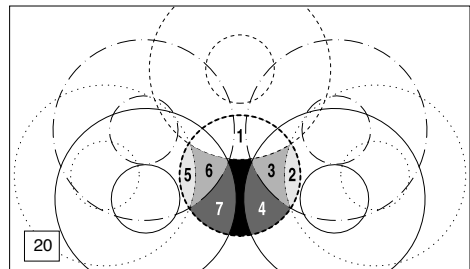
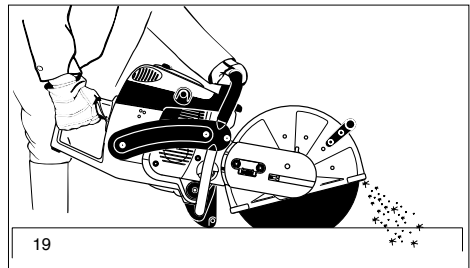

In wet cutting, the disc is wetted at an equal rate on both sides by a trickle of water. MAKITA offers the right accessories for all wet cutting applications (see also "SPECIAL ACCESSORIES").

- Remove foreign objects such as sand, stones and nails found within the working area. **Caution: Watch out for electric wires and cables!**

The rapid rotation of the cutting disc at the point of contact throws fragments out of the cut groove at high speed. For your safety, swing the protection hood down as far as possible (23), so that material fragments are thrown forward, away from the operator.

- Mark the cut, and then make a groove about 5 mm (just under 1/5") along the entire length of the planned cut. This groove will then guide the Power Cut accurately during the actual cutoff.
- Perform the cut with a steady back-and-forth motion.
- When cutting slabs to size, you need not cut through the entire material thickness (creating unnecessary dust). Instead, simply make a shallow groove, and then knock off the excess material cleanly on a flat surface (25).

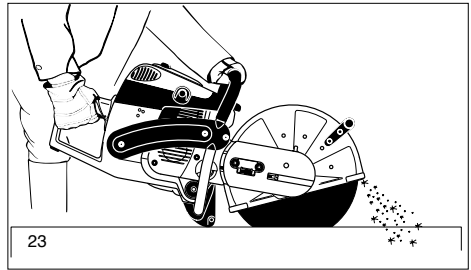

23

CAREFUL!

When cutting into lengths, cutting through material, making cutouts, etc., always make sure to plan the direction and sequence of cuts in such a way that the disc does not get jammed by the cut-off piece, and that no persons can be injured by falling pieces.

Transport and storage

- **Always turn off the Power Cut when transporting it or moving it from place to place on a site (26).**
- **Never carry or move the unit with the engine on or the disc moving!**
- Carry the unit only by the tubular (middle) handle with the cutting disc pointing behind you (26). Avoid touching the exhaust muffler (burn hazard!)
- When moving the Power Cut over longer distances, use a wheelbarrow or wagon.
- When transporting the Power Cut in a vehicle, make sure it is securely positioned in such a way that no fuel can leak out. Always remove the cutting disc before transporting the unit in a vehicle.
- The Power Cut should be stored safely in a dry place. It must not be left outdoors! Always dismount the cutting disc before storage. Keep the Power Cut away from children.
- **Before long-term storage and before shipping the Power Cut, follow the instructions in the chapter on "Periodic care and maintenance". ALWAYS empty the fuel tank and run the carburetor dry.**
- When putting cutting discs in storage, be careful to:
 - Clean and dry them well. **CAUTION: Do NOT** clean synthetic resin cutting discs with water or other fluids!
 - Store them lying down flat.
 - Avoid dampness, freezing temperatures, direct sunshine, high temperatures and temperature fluctuations, as these can cause breakage and splintering.
 - Before re-using a resin cutting disc, make sure of the use-by (expiration) date (quarter and year, stamped on the arbor ring). If this date has been exceeded, do **NOT** use the cutting disc.
- **Always check new cutting discs or cutting discs that have been in storage to make sure that they are free of defects and before the first cut test-run the tool at top speed for at least 60 seconds. Keep body parts and people well away out of range of the direction of the cutting disc during this test.**

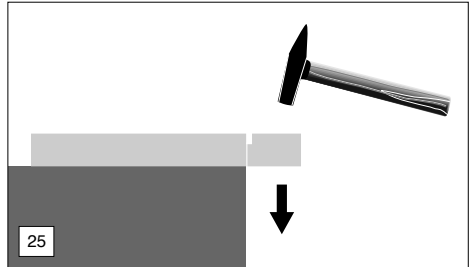

25

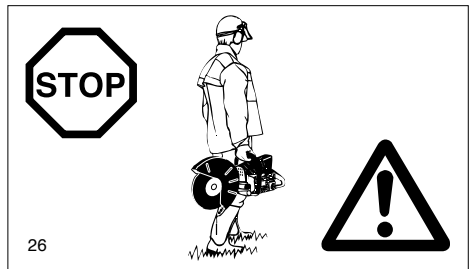

26

Maintenance

- **Before performing maintenance work switch off the Power Cut (27) and pull out the plug cap.**
- Always check the Power Cut before using it to make sure that it is in good working order. In particular, make sure that the cutting disc is properly mounted. Make sure that the cutting wheel is undamaged and suitable for the job it will be used for.
- Operate the Power Cut only at a low noise and emission level. For this ensure the carburetor is adjusted correctly.
- Clean the Power Cut regularly.
- Check the fuel tank cap regularly for good sealing.

Observe the accident prevention instructions issued by trade associations and insurance companies. NEVER make any modifications to the Power Cut! You will only be putting your own safety at risk!

Perform only the maintenance and repair works described in the instruction manual. All other work must be carried out by MAKITA Service.

Use only original MAKITA spares and accessories.

The use of non-MAKITA spares, accessories, or cutting discs increases the risk of accident. We cannot accept any responsibility for accidents or damage occurring in association with the use of cutting discs or accessories other than original MAKITA.

First aid

For the event of a possible accident, please make sure that a first aid kit is always immediately available close by. Immediately replace any items used from the first aid box.

When calling for help, give the following information:

- Place of the accident
- What happened
- Number of injured people
- Kind of injuries
- Your name!

NOTE

Individuals with poor circulation who are exposed to excessive vibration may experience injury to blood vessels or the nervous system.

Vibration may cause the following symptoms to occur in the fingers, hands or wrists: "Falling asleep" (numbness), tingling, pain, stabbing sensation, alteration of skin colour or of the skin. **If any of these symptoms occur, see a physician!**

Disposal and environmental protection

Be mindful of the environment!

Dispose of worn-out or defective cutting discs in accordance with your local disposal regulations. To protect unusable cutting discs from misuse, destroy them before disposal.

When the Power Cut is worn out or damaged beyond repair, have it disposed of or recycled in an environmentally sound manner. If necessary, consult your local authorities.

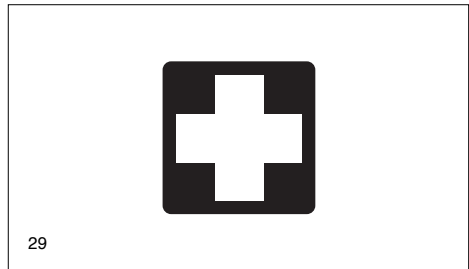
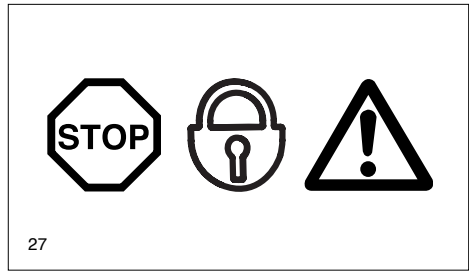

Technical data

		EK6100	EK6101
Displacement	cm ³	60,7	60,7
Bore	mm	47	47
Stroke	mm	35	35
Max. power / operating speed	kW/1/min	3,2 / 9.500	3,2 / 9.500
Max. torque	Nm	3,9	3,9
Idling speed	1/min	2.600	2.600
Clutch engagement speed	1/min	3.900	3.900
Engine speed limitation	1/min	9.850 ± 150	9.850 ± 150
Max. spindle speed	1/min	5.100	4.400
Sound pressure level L _{PA,eq} per EN 19432 ^{1) 4) 6)}	dB(A)	99,6 / K _{PA} =2,5	99,6 / K _{PA} =2,5
Sound power level L _{WA,eq} per EN 19432 ^{6) 7)}	dB(A)	108,6 / K _{WA} =2,5	108,6 / K _{WA} =2,5
Vibration acceleration a _{nv,eq} per EN 19432 ^{1) 6)}			
- Tubular handle	m/s ²	3,0 / K=2	2,7 / K=2
- Rear handle	m/s ²	3,6 / K=2	3,5 / K=2
Carburetor (diaphragm carburetor)	Type	ZAMA C3	
Ignition system (with speed limitation)	Type	electronic	
Spark plug	Type	NGK BPMR 7A	
Electrode gap	mm	0,5	0,5
Fuel consumption at max. load per ISO 8893	kg/h	1,42	1,42
Specific consumption at max. load per ISO 8893	g/kWh	430	430
Fuel tank capacity	l	0,7	0,7
Mixture ratio (fuel/two-stroke oil)			
- when using MAKITA oil		50:1	50:1
- when using other oils (quality grade: JASO FC or ISO EGD)		50:1	50:1
- when using Aspen Alkylat (two-stroke fuel)		50:1 (2%)	50:1 (2%)
Cutting disc for 80 m/sec. ²⁾	mm	300 / 20,0 / 5 ³⁾	350 / 20,0 / 5 ³⁾
Cutting disc for 80 m/sec. ^{2) 5)}	mm	--	350 / 25,4 / 5 ³⁾
Arbor diameter	mm	20,0	20,0
V-belt	no.	965 300 501	965 300 510
Overall weight (tanks empty, without cutting disc)	kg	8,5	8,8

¹⁾ Data apply to idle and rated speed operation at a ratio of 1/7 to 6/7.

²⁾ Circumference speed at max. engine speed.

³⁾ Outside diameter / arbor hole / thickness.

⁴⁾ At the workplace (at user's ear).

⁵⁾ Country-specific.

⁶⁾ Uncertainty (K=).

⁷⁾ Data apply rated speed operation.

Denomination of components

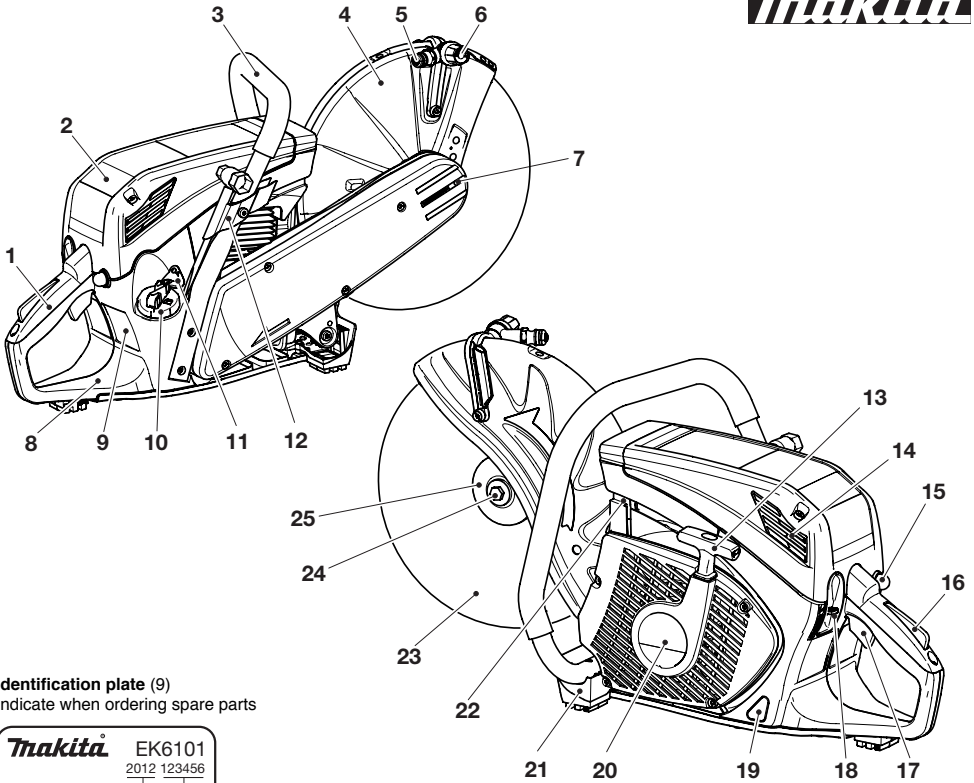

Identification plate (9)
Indicate when ordering spare parts



Serial number
Year of manufacture

- | | | | |
|----|---|----|---|
| 1 | Handle | 14 | Air intake |
| 2 | Air filter cover | 15 | Fuel pump (Primer) |
| 3 | Tubular handle | 16 | Safety locking button |
| 4 | Protection hood | 17 | Throttle lever |
| 5 | Water set | 18 | Combination switch „Choke, On/Stop (I/O)” |
| 6 | Adjusting screw | 19 | Fuel tank fill-level window |
| 7 | Hold opening | 20 | Starter housing with starter |
| 8 | Fuel tank with handle | 21 | Stand |
| 9 | Identification plate | 22 | Muffler |
| 10 | Tank cap (fuel) | 23 | Cutting disc |
| 11 | Carburetor adjustment opening | 24 | Disc bolt |
| 12 | Holder for combination tool and 1/2" hose | 25 | Spring washer |
| 13 | Starter grip | | |

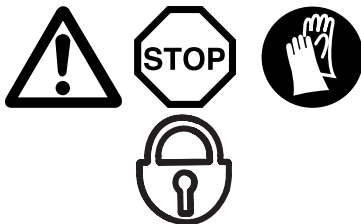

PUTTING INTO OPERATION

CAUTION:

Always **turn off the engine** and pull off the spark plug cap before doing any work on the Power Cut! Always wear protective gloves!

CAUTION:

Start the Power Cut only after complete assembly and inspection.

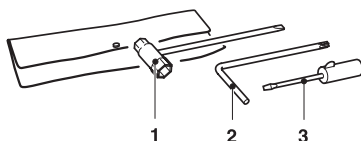

For the the following work, use the assembly tools included with delivery:

1. 13/19 AF combination wrench
2. Allen key
3. Carburetor adjustment screwdriver

Place the Power Cut on a stable surface and carry out the following assembly steps:

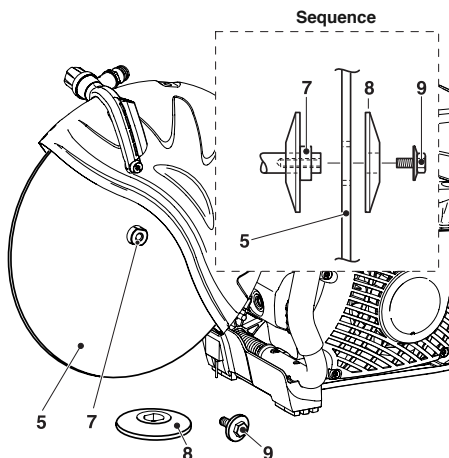

Mounting the cutting disc

Inspect the disc for damage.

See **SAFETY INSTRUCTIONS, Page 6**.

Unscrew screw (9) and remove the spring washer (8).

Place the cutting disc (5) on the arbour (7).

NOTE: The arbor hole of the cutting disc must be an exact fit with the arbor or shaft.

For cutoff discs with 25.4 mm (1") arbor holes, use the correct size disc holder (supplied only with cutoff discs with 25.4 mm (1") arbor holes).



Make sure the cutting disc is installed so it turns in the right direction, if a direction is marked on the disc.

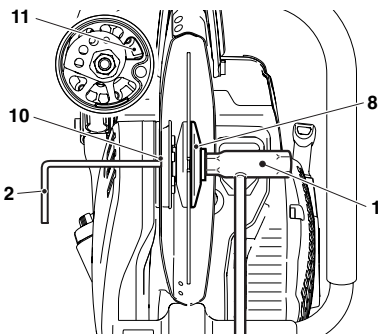

Place the spring washer (8) on the arbour and insert the screw (9) and tighten by hand.

Slowly turn the cutoff disc until a hole (11) in the V-belt pulley is visible in the counter-holding opening (10) of the cutting arm.

Insert the Allen key (2) as far as it will go. The shaft is now blocked.

Tighten the screw with the combination wrench (1).

NOTE: Tighten the screw firmly (30 ± 2 Nm), as otherwise the cutting wheel may slip during cutting.

Remove the Allen key and combination tool.

Fuel

CAUTION:

This saw is powered by mineral-oil products (gasoline and oil).

Be especially careful when handling gasoline.
Avoid all flame or fire. Do not smoke (explosion hazard).



Fuel mixture

This tool is powered by a high-performance air-cooled two-stroke engine. It runs on a mixture of gasoline and two-stroke engine oil.

The engine is designed for unleaded regular gasoline with a min. octane value of 91 ROZ. In case no such fuel is available, you can use fuel with a higher octane value. This will not affect the engine.

In order to obtain an optimum engine output and to protect your health and the environment use unleaded fuel only.

To lubricate the engine, use a synthetic oil for two-stroke air-cooled engines (quality grade JASO FC or ISO EGD), which has to be added to the fuel. The engine has been designed for use of MAKITA high-performance two-stroke engine oil and a mixture ratio of only 50:1 to protect the environment. In addition, a long service life and reliable operation with a minimum emission of exhaust gases are ensured.

MAKITA high-performance two-stroke engine oil is available in the following sizes to suit your individual requirements:

100 ml	order number 980 008 606
1 l	order number 980 008 607

In case MAKITA high-performance two-stroke engine oil is not available, it is urgently recommended to use a mixture ratio of 50:1 with other two-stroke engine oils (quality grade: JASO FC or ISO EGD), as otherwise optimum operation of the engine cannot be guaranteed.

Caution: Do not use ready-mixed fuel from petrol stations.

The correct mixture ratio:

50:1 when using MAKITA high-performance two-stroke engine oil, i. e. mix 50 parts gasoline with 1 part oil.

50:1 when using other synthetic two-stroke engine oils (quality grade JASO FC or ISO EGD), i. e. mix 50 parts gasoline with 1 part oil.

NOTE: For preparing the fuel-oil mixture first mix the entire oil quantity with half of the fuel required, then add the remaining fuel. Thoroughly shake the mixture before filling it into the chain saw tank.

Caution: Open the tank cap carefully, as pressure might have built up inside!

Gasoline	+	50:1	50:1
1000 cm ³ (1 litre)		20 cm ³	20 cm ³
5000 cm ³ (5 litre)		100 cm ³	100 cm ³
10000 cm ³ (10 litre)		200 cm ³	200 cm ³

It is not wise to add more engine oil than specified to ensure safe operation. This will only result in a higher production of combustion residues which will pollute the environment and clog the exhaust channel in the cylinder as well as the muffler. In addition, fuel consumption will rise and performance will decrease.

The Storage of Fuel

Fuels have a limited storage life. Fuel and fuel mixtures age through evaporation, especially at high temperatures. Aged fuel and fuel mixtures can cause starting problems and damage the engine.

Purchase only that amount of fuel, which will be consumed over the next few months. At high temperatures, once fuel has been mixed it should be used up in 6-8 weeks.

Store fuel only in proper containers, in dry, cool, secure locations!



AVOID SKIN AND EYE CONTACT

Mineral oil products degrease your skin. If your skin comes in contact with these substances repeatedly and for an extended period of time, it will desiccate. Various skin diseases may result. In addition, allergic reactions are known to occur.

Eyes can be irritated by contact with oil. If oil comes into your eyes, immediately wash them with clear water. If your eyes are still irritated, see a doctor immediately!



Refuelling IMPORTANT:

FOLLOW THE SAFETY PRECAUTIONS!

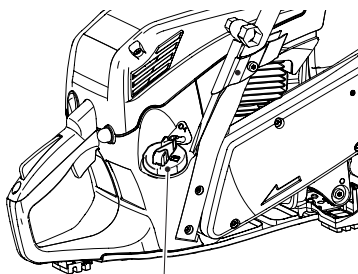

Fuel mixture

Be careful and cautious when handling fuels.

The engine must be turned off and cooled down!

Carefully clean the area around the fuel-tank filler neck to keep dirt from getting in the tank.

Place the Power Cut on an even surface.

Unscrew the tank cap and fill tank with fuel mixture. Take care to avoid spilling.

Screw the tank cap back on hand-tight.

Clean screw cap and tank after refuelling. Never start or operate the Power Cut in the same place as it was fuelled!

If fuel gets on your clothing, change clothes immediately.



3 Meter

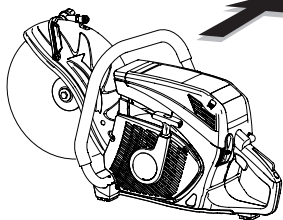

Starting the engine



necessary

CAUTION:

Observe the SAFETY INSTRUCTIONS on page 4 and 5!

Start the Power Cut only after complete assembly and inspection!

Move at least 3m away from the place where you fuelled the Power Cut.

Make sure you have a good footing, and place the Power Cut on the ground in such a way that the cutting disc is not touching anything.

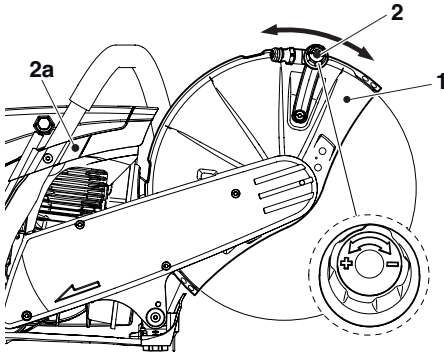

Move the protective hood (1) into the proper position for the work you intend to do (see illustration).

The protective hood (1) can be moved between the stops in both directions.

Note: A water supply line (from a pressurized water tank or other source) is connected by the water set on the protective hood. The water flow rate can be adjusted with the adjusting screw (2). Press the 1/2" hose into the holder (2a).

For a slower flow, turn the adjusting screw clockwise.
For a faster flow, turn it counter-clockwise.

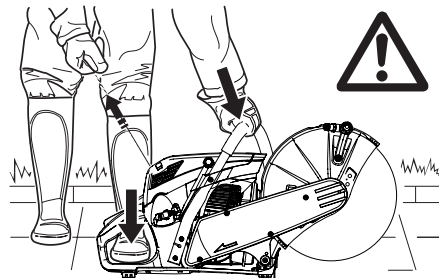

Cold starting:

Grasp front handle firmly with one hand and press the Power Cut against the ground.

Place left toe in the rear handguard.

Prime the fuel pump (4) by pressing it several times until you can see fuel in the pump.

Move the combination switch (3) up (choke position). This also actuates the half-throttle lock.

Pull starter handle smoothly and evenly, until you hear the first ignition (but max. 3-5 pulls).

CAUTION: Do not pull the starter cable more than about 50 cm/20" out, and let it back in slowly by hand.

Move the combination switch (3) to the central "ON" position. Pull the starter handle smoothly and evenly again.

As soon as the engine is running, grasp the rear handle (the safety lock button (5) is actuated by the palm of the hand) and press the throttle trigger lock (6). The half-throttle lock will disengage and the engine will now idle.

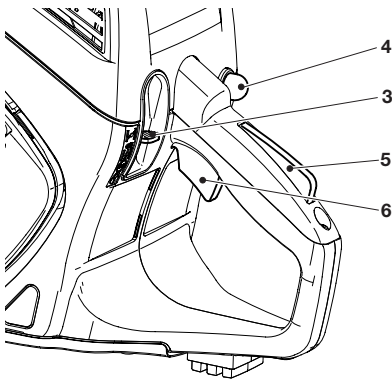

Warmstart:

As described above for cold starting, but before starting push the combination switch (3) up (Choke position) and then right away back to the middle "ON" position. This is only to engage the half-throttle lock. If the engine doesn't start after 2 or 3 pulls, repeat the entire starting procedure as described for cold starting.

NOTE: If the engine was switched off only for a short time, the saw can be started without using the combination switch.

Important: If the fuel tank has been completely emptied and the engine has stopped due to lack of fuel prime the fuel pump (4) by pressing it several times until you can see fuel in the pump.

Stopping the engine

Depress the combination switch  (3).

NOTE: After being pressed down, the combination switch will revert to the "ON" position again. The engine is switched off, but can be turned on again without moving the combination switch.

IMPORTANT: To cut off the ignition current, push the combination switch all the way down past the resistance point to the safety position ().

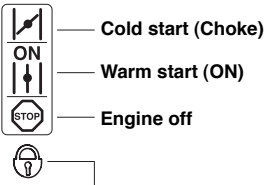

Combination switch in safety position

(ignition current cut off, necessary for all maintenance, repair, and installation work)

Adjusting the carburetor



NOTE: The grinding parts are equipped with an electronic ignition to limit the speed.

At the factory the idling speed has been set to approx. 2600 rpm, but the running-in process of a new engine may require slight readjustment of the idling speed.

Adjustments to the adjusting screws (L) and (H) may only be made by an authorised MAKITA service centre.

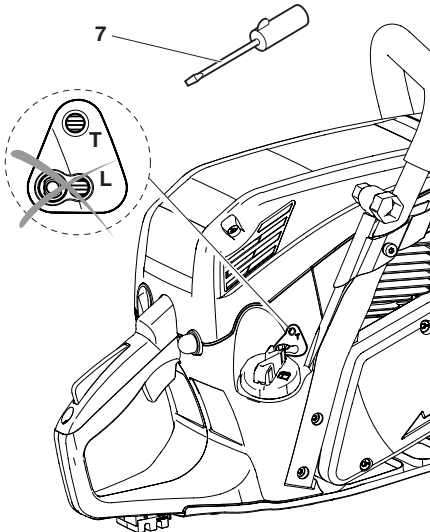

For correct adjustment of the idling speed the following steps must be carried out:

Start the engine and run it until it is warm (about 3 - 5 minutes).

Adjust the carburetor with the screwdriver (7, Order No. 944 340 001) included with the Power Cut. It has a lug that helps with adjustment.

Readjust the idling speed.

If the cutoff disc turns when the engine is idling, turn the throttle stop screw (T) counter-clockwise in small increments until the disc no longer turns.

If the engine suddenly stops in idle, turn the screw back slightly clockwise.

Switch off the engine.

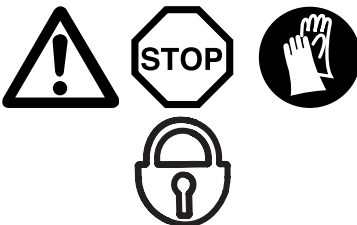

MAINTENANCE

CAUTION:

Before doing any work on the Power Cut **turn off the engine**, remove the cutting disc, pull the plug cap off the spark plug and wear protective gloves!

CAUTION:

Start the Power Cut only after complete assembly and inspection.



SERVICE

IMPORTANT:

Because many of the parts and assemblies not mentioned in this Instruction Manual are vital to the safety of the unit, and because all parts are subject to a certain amount of wear and tear, it is important for your own safety that you have the unit checked and maintained regularly by a MAKITA service center.

IMPORTANT:



If the cutting wheel breaks during cutting, the Power Cut must be repaired by a MAKITA service centre before being used again!

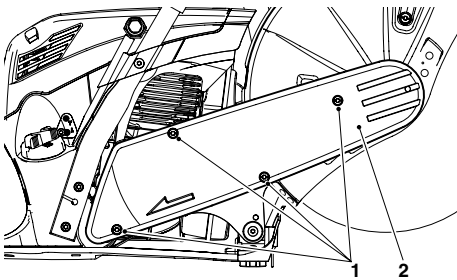

Changing the V-belt

Loosen bolts (1) and remove belt cover (2).

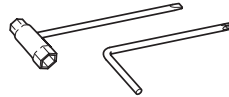

Move the V-belt pulley into the position shown.

Insert the Allen key into the hole (3) to block the V-belt pulley (5).

Note: Make sure that the V-belt pulley remains blocked.

Use the combination tool to turn the nut (4) about one turn counter-clockwise.

Use the combination tool to turn the eccentric (6) forcefully counter-clockwise to the position shown.

Remove the old V-belt (7) or belt fragments.

Clean out the interior with a brush.

Insert a new V-belt.

Use the combination tool to turn the eccentric (6) forcefully clockwise to its original position (V-belt is now tight).

Tighten the nut (4).

Remove Allen key from hole (3).

Put the belt cover (2) on and tighten the bolts (1).

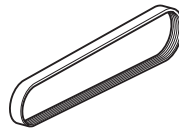
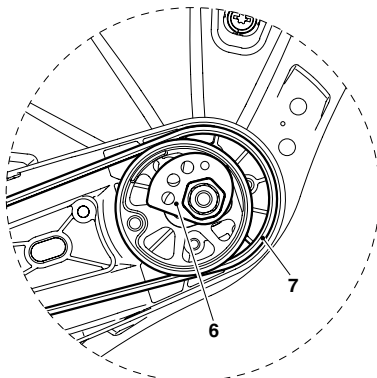
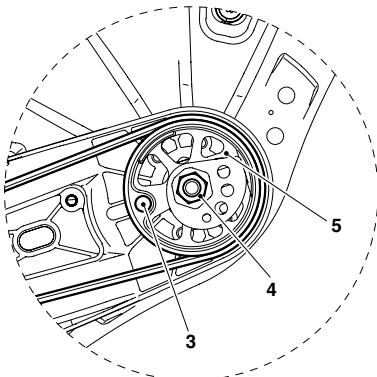

Note: The V-belt is highly elastic, so it is not necessary to retighten it.

A worn V-belt causes the cutoff disc turns at the lowest idle speed. In this case, the V-belt must be replaced!

Cleaning the protection hood

Over time, the inside of the protective hood can become caked with material residue (especially from wet cutting), which if allowed to accumulate can hinder the free rotation of the cutting disc. For this reason the hood must be cleaned out from time to time.

Take off the cutting wheel with spring washer and remove the accumulated material from inside the hood with a strip of wood or similar implement.

Clean the shaft and all removed parts.



NOTE: To install the cutting wheel see "Mounting the cutting wheel".

Cleaning / changing the air filter

CAUTION:

Turn off the engine before cleaning the air filter! Never clean out the air filter with compressed air! Do not use fuel to clean the air filter insert (3) and inner filter (6).

The service life of the engine depends on the condition and regular maintenance of the filter elements. Failure to perform maintenance and cleaning at the prescribed intervals will cause increased wear inside the engine!

If the air filter becomes damaged, replace immediately! Pieces of cloth or large dirt particles can destroy the engine! Do not work in dusty conditions when it can be avoided!

The fine dust generated when dry-cutting concrete and stone is hazardous to the health of the operator and also shortens the service life of the engine. Whenever possible, wet-cut with water when working in concrete and stone, to bind the dust.

Loosen both bolts (1) and remove the filter cover (2).

Take the air filter cover (3) out of the cover (5).

Loosen the six bolts (4) on the cover and remove the cover.

Remove the inner filter (6).

When reassembling, make sure that the two lugs (7) of the filter cover engage in the cover (5).

Inner filter

Wash out the dirty inner filter (6, Order No. 315 173 020) in lukewarm soapy water with regular dishwashing liquid.

Let the inner filter **dry thoroughly**.

Air filter insert (paper cartridge)

The air filter insert (3, Order No. 315 173 010) filters the intake air through a very fine paper filter lamella system. For this reason the cartridge must never be washed or cleaned with compressed air. Clean the air filter insert once per month.

To clean the air filter insert, spread it out slightly and carefully tap it against a clean surface.

Replace the air filter insert every 500 operating hours. Replace it immediately if there is a drop in power, drop in speed, or smoke in the exhaust.

Before installing the filter system, check the intake opening to make sure no dirt particles have fallen in. If they have, remove them.

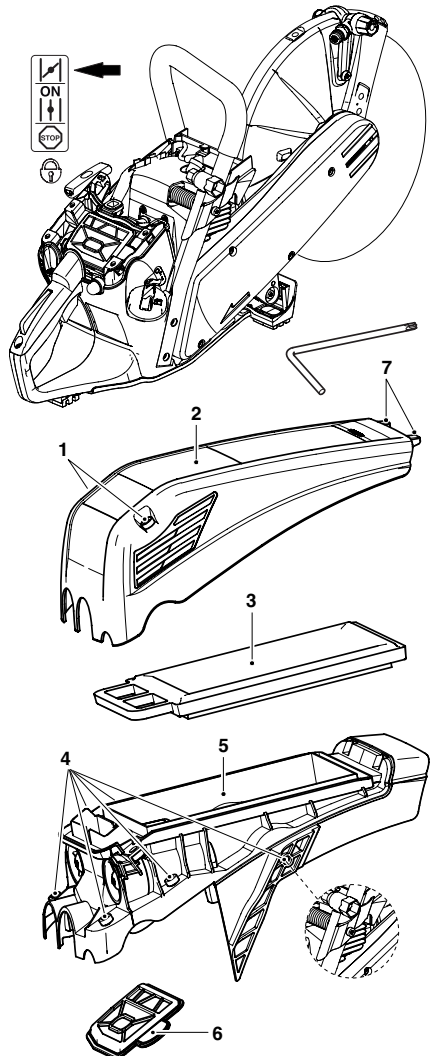

Replacing the spark plug



CAUTION:

Do not touch the spark plug or plug cap if the engine is running (high voltage).

Switch off the engine before starting any maintenance work.

A hot engine can cause burns. Wear protective gloves!

The spark plug (Order No. 965 603 021) must be replaced in case of damage to the insulator, electrode erosion (burn) or if the electrodes are very dirty or oily.

Remove the filter cover and hood. See **Cleaning / changing the air filter**.

Pull the plug cap (1) off the spark plug. Use only the combination wrench supplied with the saw to remove the spark plug.

CAUTION: To prevent damage to the decompression valve (8), when unscrewing the spark plug position the combination tool in such a way that it does not impact the valve.

Electrode gap

The electrode gap must be 0.5 mm.

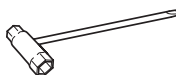
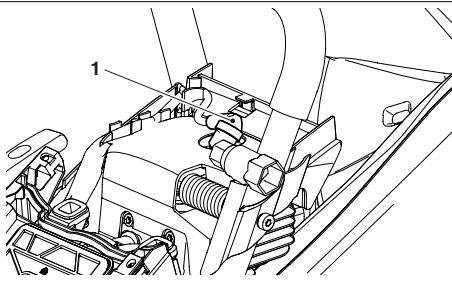

CAUTION: Use only NGK BPMPR 7A spark plug.

Other spark plugs can damage the ignition system!

Checking the ignition spark

Insert the combination tool (2) between the ventilation hood and cylinder only as shown in the illustration.

CAUTION!

Do **not** insert the combination tool into the spark plug hole, but make contact **only** with the cylinder (otherwise you may damage the engine).

Using insulated pliers, hold the spark plug (3) (unscrewed but with the plug cap on) against the combination tool (away from the spark plug hole!).

Switch the combination switch (4) to "ON".

Pull the starter cable hard.

If the function is correct, an ignition spark must be visible near the electrodes.

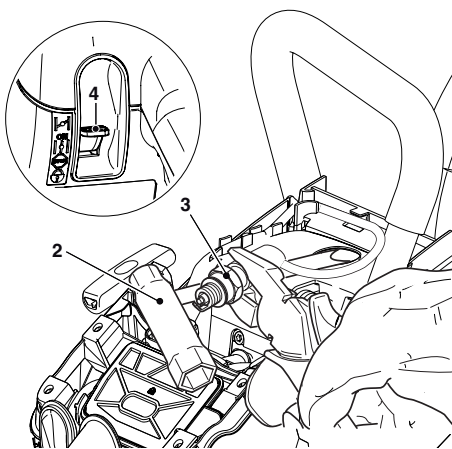

Replacing the suction head

The felt filter (5) of the suction head can become clogged. It is recommended to replace the suction head once every three months in order to ensure unimpeded fuel flow to the carburetor.

Unscrew the tank cap (6), pull the retainer out of the opening. Empty fuel tank.

Use a wire hook to pull the suction out of the tank opening for replacement.

Caution: Do not allow fuel to come into contact with skin!

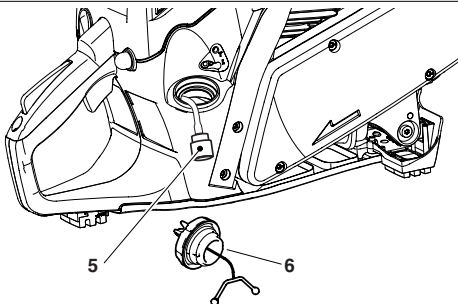

Replacing the return spring pack/Replacing the starter spring

Remove the fan housing (see "Replacing the starter cable").

Remove the air guide from the fan housing (see "Replacing the starter cable").

Detension the return spring on the cable drum and remove the cable drum (see "Replacing the starter cable").

Note: Unspool the starter cable from the drum only. Do not pull it out of the cable drum or the starter grip!

CAREFUL! Injury hazard! The return spring can pop out! Always wear eye protection and protective gloves!

Lightly tap the fan housing on a wooden surface with the entire surface of the hollow side, and **hold it down**. Now lift the fan housing **carefully and in small steps**. This will allow the return spring pack (13), which should now have fallen out, to relax in a controlled manner if the return spring has popped out of the plastic pack.

If the return spring pops out, it can be wound back into the cassette as shown (15). Make sure the direction of winding is correct.

Carefully insert a new return spring cassette and press down until it engages.

Put the cable drum (5) and spring back on, and turn it slightly until the return spring catches.

Put on the carrier (8) and bolt it on with bolt (7).

Tension the return spring (see "Replacing the starter cable").

Replacing the starter spring

NOTE: If the spring (6) in the Featherlight-Starting system is broken, more effort will be required to start the engine and you will notice some resistance when pulling the starter cable.

If you notice this, check the spring (6) and replace if necessary.

Mounting the fan housing

Insert the air guide (3) in the fan housing so that the five recesses (4) engage.

Position the fan housing on the machine, apply slight counter-pressure, and pull the starter grip until the starter mechanism catches.

Tighten screws (1).

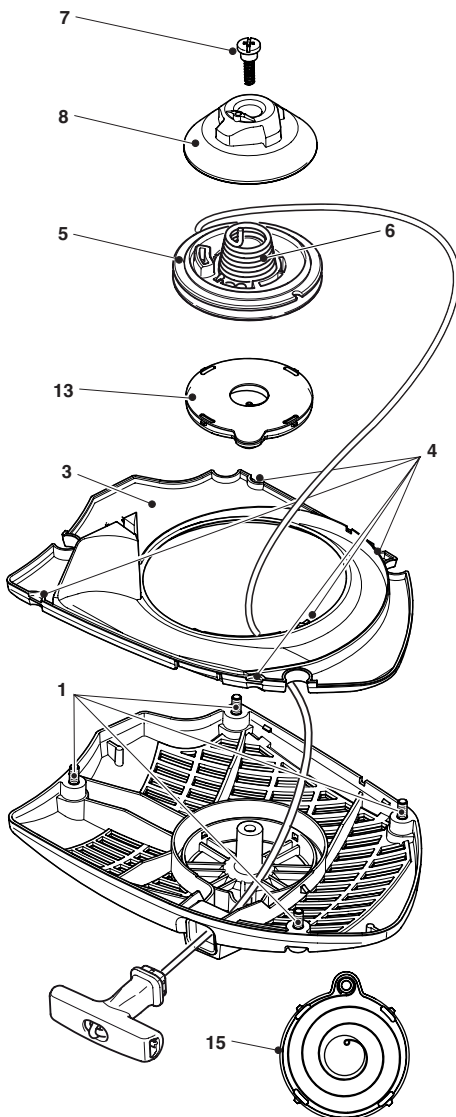

Instructions for periodic maintenance

To ensure long life, prevent damage and ensure the full functioning of the safety features the following maintenance must be performed regularly. Guarantee claims can be recognized only if this work is performed regularly and properly. Failure to perform the prescribed maintenance work can lead to accidents!

Users of the Power Cut must not perform any maintenance work not described in this Instruction Manual. All such work must be carried out by a MAKITA service centre.

			Page
General	Entire Power Cut	Clean exterior, check for damage. In case of damage, have repaired by a qualified service centre immediately	
	Cutting disc	Inspect regularly for damage and wear.	6
	Clutch	Have inspected at a service center.	
	Protection hood	Clean	19
Before each start	Cutting disc	Inspect for damage and make sure the cutting wheel is right for the job	6
	Protective hood	Adjust position	16
	Combination switch, Safety locking button, Throttle lever	Functional check Functional check Functional check	16
	Tank cap	Check for tightness	
Every day	Idle speed	Check (cutting disc must not turn on idle)	17
Every week	Starter housing	Clean to ensure proper air cooling	12
	Starter cable	Check for damage	21
	V-belt	Inspect for damage and wear	18
	Spark plug	Check and replace if necessary	20
	Muffler	Check tightness of mounting	12
	Screws and nuts	Check their condition and that they are firmly secured.	
Monthly	Air filter insert	Clean, replace after 500 operating hours	19
Every 3 months	Suction head	Replace	20
	Fuel tank	Clean	
Annually	Entire Power Cut	Check at an authorized service centre	
Storage	Entire Power Cut	Clean exterior, check for damage. In case of damage, have repaired by a qualified service centre immediately	
	Cutting disc	Remove and clean	13
	Fuel tank	Empty and clean	
	Carburetor	Run empty	

Service, spare parts and guarantee

Maintenance and repair

The maintenance and repair of modern cutoff saws and their safety-related components requires qualified technical training and a workshop equipped with special tools and testing devices.

We therefore recommend that you consult a MAKITA service centre for all work not described in this instruction manual.

The MAKITA service centres have all the necessary equipment and skilled and experienced personnel, who can work out cost-effective solutions and advise you in all matters.

To find your local distributor, please visit www.makita-outdoor.com

Spare parts

Reliable long-term operation, as well as the safety of your Power Cut, depend among other things on the quality of the spare parts used. Use only original MAKITA parts, marked



Only original parts are from the same production line as the original unit and therefore ensure the highest possible quality of materials, dimensions, functioning and safety.

Only original spare parts and accessories guarantee the highest quality in material, dimensions and function.

Original spare parts and accessories can be obtained from your local dealer. He will also have the spare part lists to determine the required spare part numbers, and will be constantly informed about the latest improvements and spare part innovations.

Please bear in mind that if parts other than original MAKITA spare parts are used, this will automatically invalidate the MAKITA product guarantee.

We will furthermore not accept any liability damages arising from the use of non-MAKITA spare parts.

Guarantee

MAKITA guarantees the highest quality and will therefore reimburse all costs for repair by replacement of damaged parts resulting from material or production faults occurring within the guarantee period after purchase. Please note that in some countries particular guarantee conditions may exist. If you have any questions, please contact your salesman, who is responsible for the guarantee of the product.

Please note that we cannot accept any responsibility for damage caused by:

- Disregard of the instruction manual.
- Non-performance of the required maintenance and cleaning.
- Incorrect carburetor adjustment.
- Normal wear and tear.
- Obvious overloading due to permanent exceeding of the upper performance limits.
- The use of other than original MAKITA cutting discs.
- Use of force, improper use, misuse or accidents.
- Damage from overheating due to dirt on the fan housing.
- Work on the Power Cut by unskilled persons or inappropriate repairs.
- Use of unsuitable spare parts or parts which are not original MAKITA parts, insofar as they have caused the damage.
- Use of unsuitable or old oil.
- Damage related to conditions arising from lease or rent contracts.
- Damages caused by disregarding loose outer bolted connections.

Cleaning, servicing and adjustment work is not covered by the guarantee. All repairs covered by the guarantee must be performed by a MAKITA service centre.

Troubleshooting

Malfunction	System	Observation	Cause
Cutting disc does not start turning	Clutch	Engine runs	Damage to clutch
Cutting disc runs in idle	Carburetor, clutch V-belt	Cutting disc runs	Incorrect idle speed, blocked clutch Belt has insufficient tension, V-belt is worn
Engine does not start or only with difficulty	Ignition system Fuel supply Compression system Mechanical malfunction	Ignition spark No ignition spark Fuel tank is filled Inside Outside Starter does not engage	Malfunction in fuel supply system, compression system, mechanical malfunction. Switch on STOP, fault or short-circuit in the wiring, plug cap or spark plug defective. Choke in wrong position, carburetor defective, suction head dirty, fuel line bent or interrupted. Cylinder base packing ring defective, radial shaft packings defective, cylinder or piston rings defective Spark plug does not seal. Spring in starter broken, broken parts inside the engine.
Warm start difficulties	Carburetor	Fuel tank is filled	Wrong carburetor adjustment. Ignition spark
Engine starts, but dies immediately	Fuel supply	Fuel tank is filled	Wrong idling adjustment, suction head or carburetor dirty. Tank venting defective, fuel line interrupted, cable defective, STOP switch defective. Decompression valve dirty
Insufficient power	Several systems may be involved simultaneously	Engine is idling	Air filter dirty, wrong carburetor adjustment, muffler clogged, exhaust channel in cylinder clogged.

SPECIAL ACCESSORIES

Diamond cutting discs

MAKITA diamond cutting discs meet the highest demands in working safety, ease of operation, and economical cutting performance. They can be used for cutting all materials **except metal**.

The high durability of the diamond grains ensures low wear and thereby a very long service life with almost no change in disc diameter over the lifetime of the disc. This gives consistent cutting performance and thus high economy. The outstanding cutting qualities of the discs make cutting easier.

The metal disc plates give highly concentric running for minimal vibration during use.

The use of diamond cutting discs reduces cutting time significantly. This in turn leads to lower operating costs (fuel consumption, wear on parts, repairs, and last but not least environmental damage).

Pressurized water tank

To keep down dust and for better cutting-disc cooling, MAKITA offers several options for wetting the disc during operation.

The pressurized water tank is connected to the Power Cut by the water set on the protective hood.

See "Accessories" for order number.

Extract from the spare parts list

Use only original MAKITA parts. For repairs and replacement of other parts, see your MAKITA service centre.

EK6100

EK6101

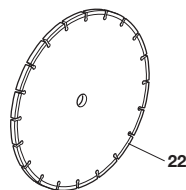
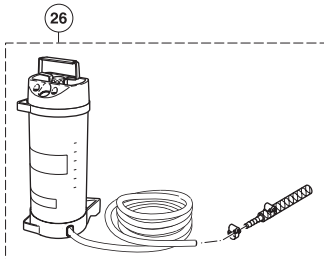
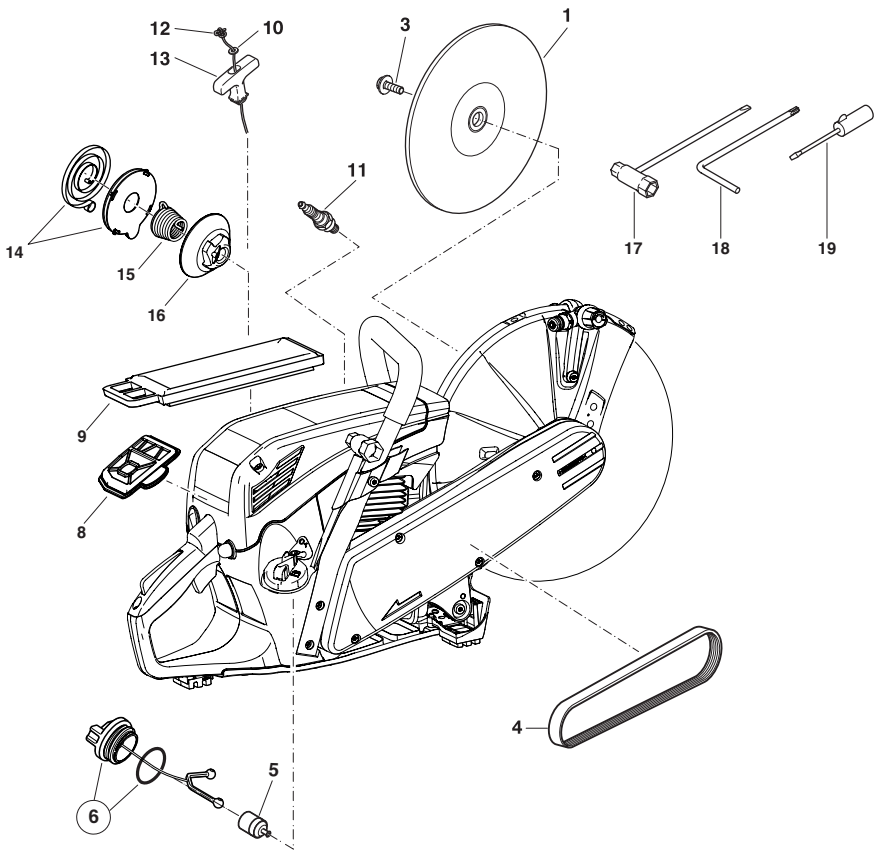

Extract from the spare parts list

Use only original MAKITA parts. For repairs and replacement of other parts, see your MAKITA service centre.

EK6100

EK6101



Pos.	MAKITA-No.	Qty.	Denomination
Synthetic resin cutting disc			
1	966 121 150	1	Cutting disc for steel, dia. 300/20 mm
	966 141 150	1	Cutting disc for steel, dia. 350/20 mm
	966 144 150	1	Cutting disc for steel, dia. 350/25,4 mm
1	966 121 120	1	Cutting disc for masonry, dia. 300/20 mm
	966 141 120	1	Cutting disc for masonry, dia. 350/20 mm
	966 144 120	1	Cutting disc for masonry, dia. 350/25,4 mm
Diamond cutting disc			
22	966 244 632	1	Cutting disc for masonry, dia. 350/25,4 mm
3	994 290 250	1	Hex screw M8x25
4	965 300 501	1	V-belt (EK6100)
	965 300 510	1	V-belt (EK6101)
5	963 601 122	1	Suction head
6	315 114 350	1	Tank cap, compl. (fuel)
8	315 173 020	1	Inner filter
9	315 173 010	1	Air filter insert (paper cartridge)
10	395 405 000	1	Disk 5
11	965 603 021	1	Spark plug
12	395 164 010	1	Starter cable ø 3,8x1000 mm
13	181 164 010	1	Starter grip
14	181 163 050	1	Return spring in housing
15	181 163 080	1	Spring
16	181 163 090	1	Driver
17	941 719 131	1	Universal wrench SW 13/19
18	940 827 000	1	Offset screwdriver T27
19	944 340 001	1	Screwdriver (carburetor)

Accessories (not delivered with the Power Cut)

Diamond cutting disc			
22	966	1	Please consult your MAKITA dealer!
26	957 802 600	1	Pressure water tank, cpl.
-	949 000 035	1	Combined can (for 5l fuel, 2.5l oil)

To find your local distributor, please visit
www.makita-outdoor.com



MAKITA Corporation
3-11-8 Sumiyoshi-Cho
Anjo, Aichi
446-8502 Japan

Specifications subject to change without notice

Form: 995 704 531 (2012-10 GB)