

# Cricket

February 2011

## Operator's Manual

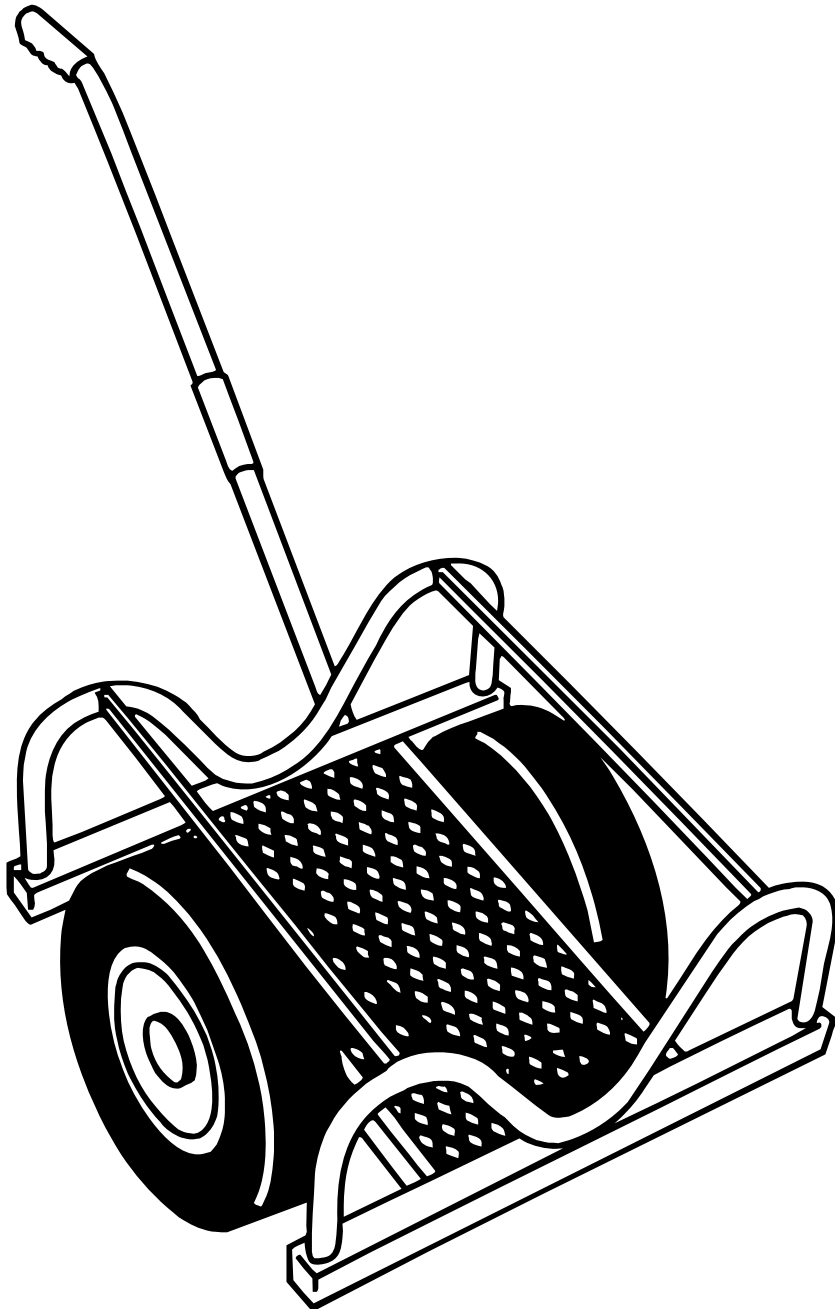

# SUMNER

---

### US

7514 Alabonson Road  
Houston, TX 77088  
phone: 281-999-6900  
fax: 281-999-6966

### Canada

470 Collier MacMillan Drive, Unit 2 & 3  
Cambridge, ON N1R 5Y7  
phone: 519-623-2300  
fax: 519-623-0744

### UK

Unit 16A  
Blackpole Trading Estate East  
Blackpole Road  
Worcester, WR3 8SG  
phone: (44) 01905 458333  
fax: (44) 01905 458222

**Capacity: 1,000 lbs / 450 kg**

**Weight: 70 lbs / 32 kg**

## **OPERATING THE HOLD-DOWN STRAP**

**Fig. 1**

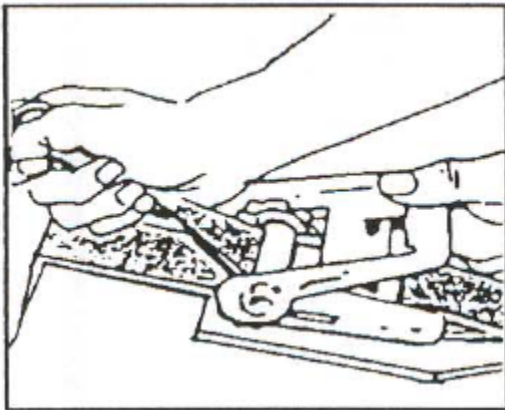

Insert end of strap through slot in ratchet reel and pull until snug.

**Fig. 2**

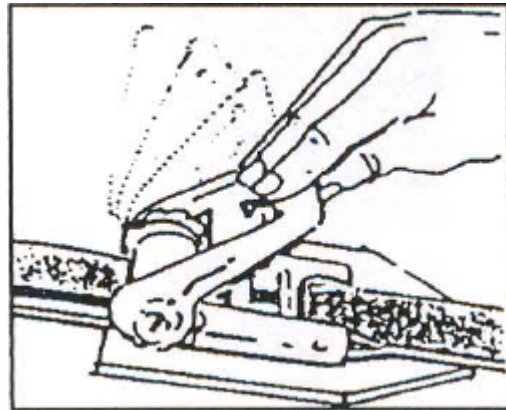

Tighten the strap by pumping the handle until secure. A minimum of two turns of webbing should be around the reel after tensioning.

**Fig. 3**

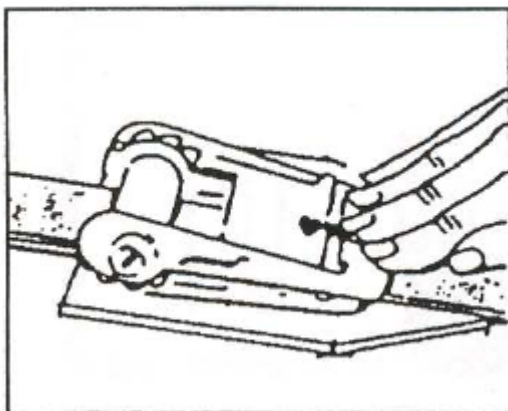

When straps are tight, put handle down flat to lock and hold the load.

**Fig. 4**



To release, pull back on handle latch and rotate the handle approximately 180°.

# LOADING A PIPE

**Fig. 1**



Remove handle.

**Fig. 2**



Place strap under pipe by rolling pipe.

**Fig. 3**



Put Cricket on top of pipe and ratchet strap tightly

**Fig. 4**



Put handle through tube sleeve on underside of Cricket.

**Fig. 5**



Put handle in upright position. Using leverage, lift cart up and walk over pipe.

**Fig. 6**



**Fig. 7**



Continue to pull handle to flip Cricket onto its wheels. Rotate handle 180° as cart repositions.

**Fig. 8**



Replace handle to the original position and secure with plunger pin.

# 782699 – CRICKET ASSEMBLY

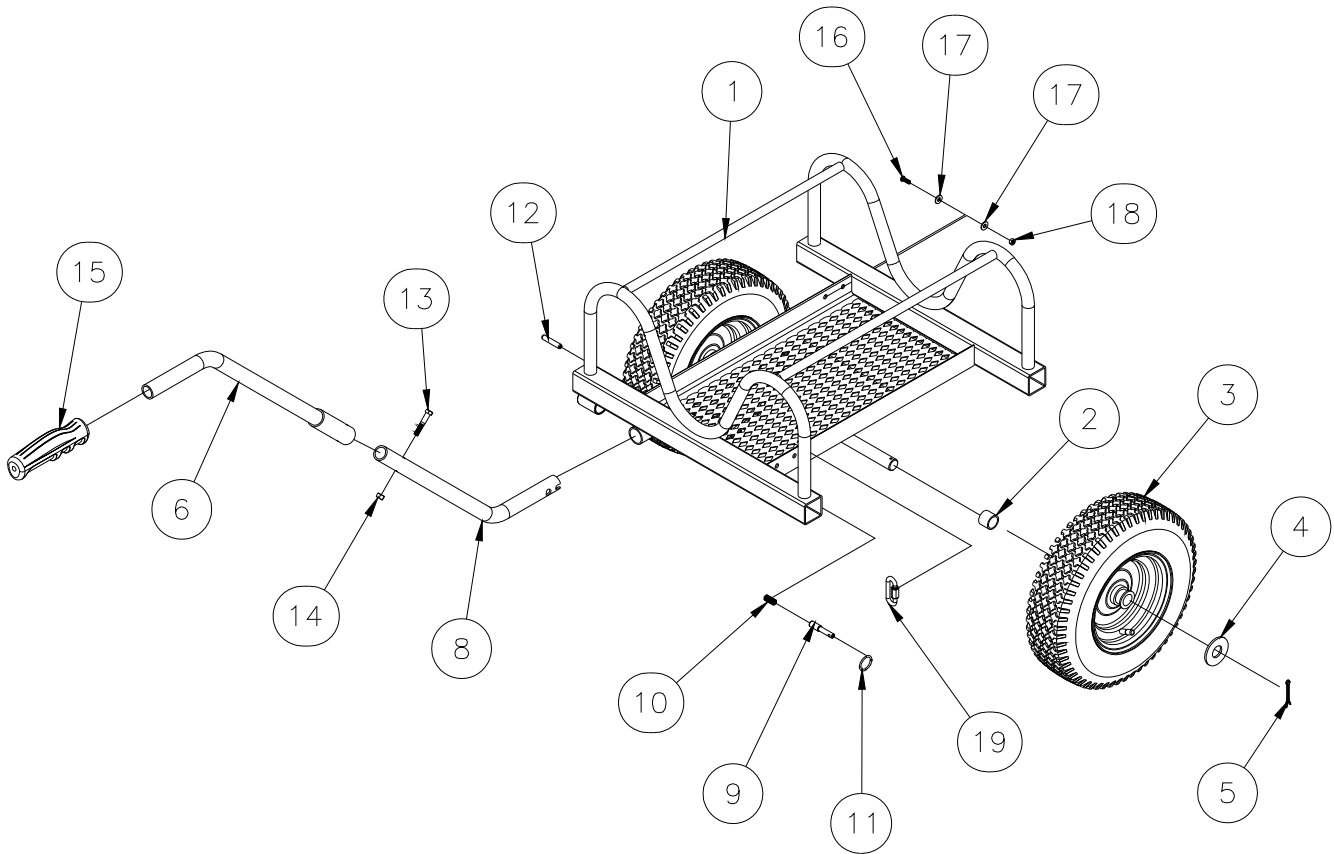

TIE-DOWN STRAP AND BUCKLE NOT SHOWN  
(ITEMS 20 AND 21)

21	779111	1	TIE-DOWN STRAP AND HOOK
20	779110	1	TIE-DOWN RACHET BUCKLE
19	779315	1	RAPID LINK
18	772076	1	NUT, INSERT LOCK 1/4-20
17	773020	2	WASHER, FLAT 1/4
16	771046	1	BHCS, 1/4-20 X 3/4
15	779112	1	HANDLE GRIP, BLACK
14	772355	1	NUT, INSERT LOCK 3/8-16
13	771112	1	HHCS, 3/8-16 X 2
12	774090	1	PIN, ROLL 3/8 X 2
11	775110	1	SPLIT RING, 1-1/4
10	776212	1	SPRING, PLUNGER
9	784510	1	PLUNGER
8	782734	1	LOWER HANDLE, CRICKET
6	782733	1	UPPER HANDLE WELDMENT, CRICKET
5	774049	2	COTTER PIN, BRASS 3/16 X 1-1/2
4	773100	2	WASHER, FLAT 1" USS
3	779107	2	480/400 X PNEUMATIC WHEEL & TIRE
2	782738	2	WHEEL SPACER, CRICKET
1	782730	1	CRICKET FINAL WELDMENT
Item	Part No.	Qty	Description
Parts List			