

HILTI

TE 2/TE 2-S/ TE 2-M

Operating instructions	en
Brugsanvisning	da
Bruksanvisning	sv
Bruksanvisning	no
Käyttöohje	fi
Инструкция по эксплуатации	ru
Ръководство за обслужване	bg
Manual de utilizare	ro
Kullanım kılavuzu	tr
دليل الاستعمال	ar
Lietošanas pamācība	lv
Instrukcija	lt
Kasutusjuhend	et
Пайдалану бойынша басшылық	kk
取扱説明書	ja
사용설명서	ko
操作說明書	zh
操作说明书	cn

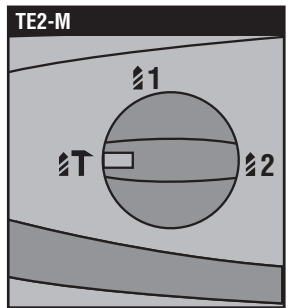

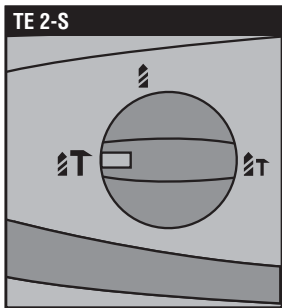
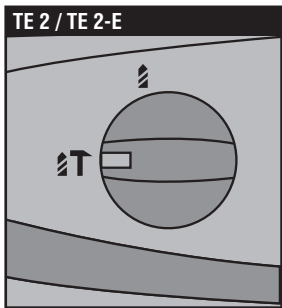
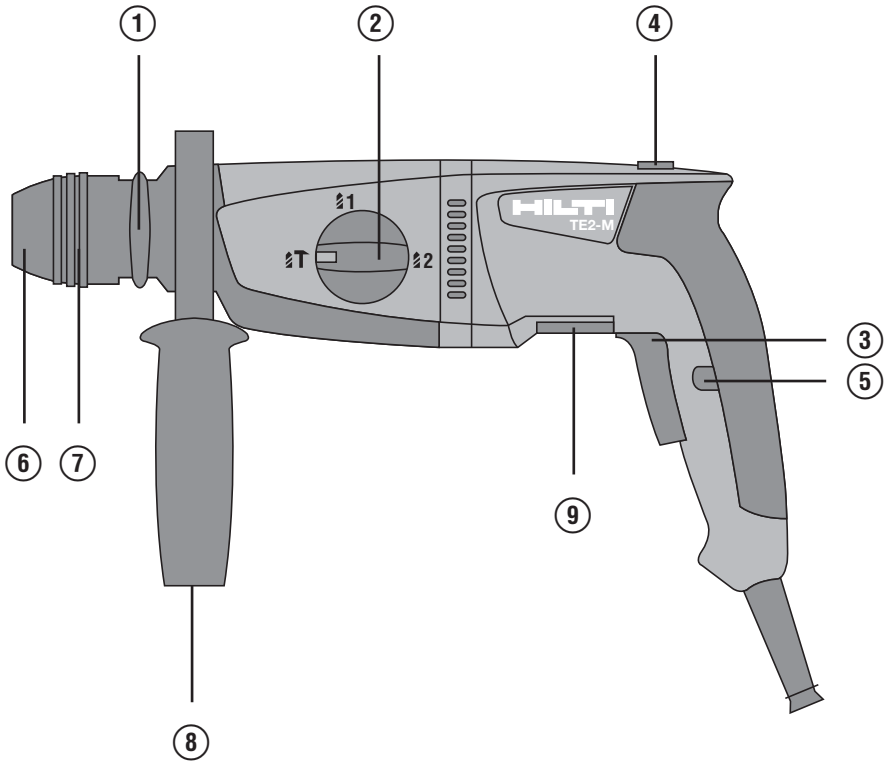

2 TE2-M

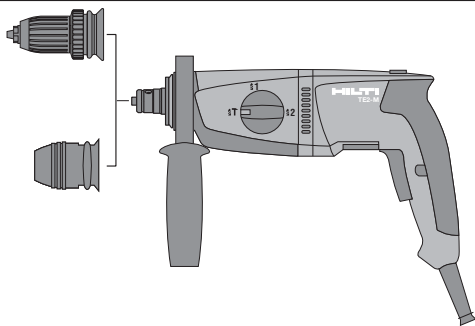

3 TE2-M

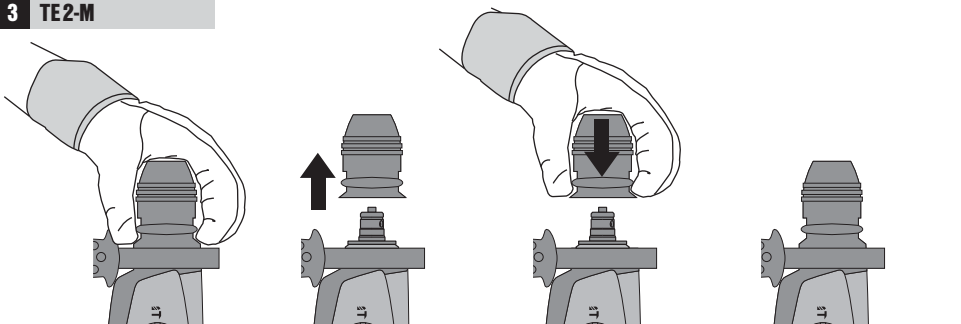

4

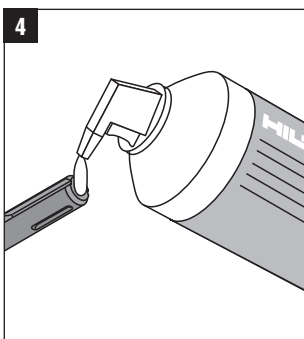

5a

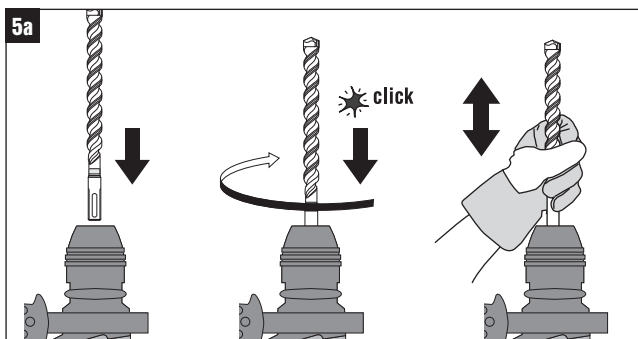

5b

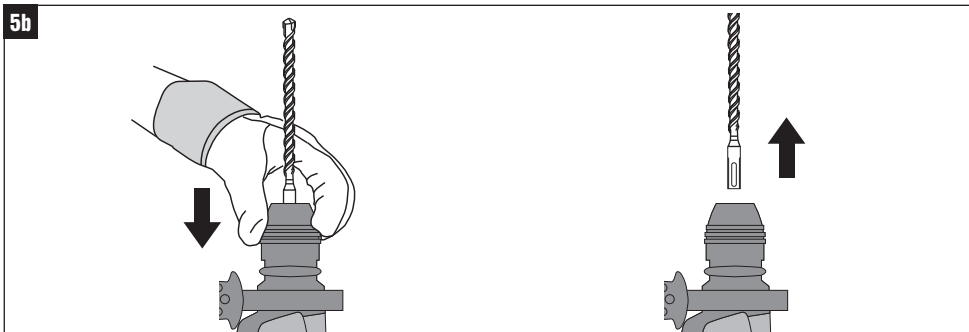

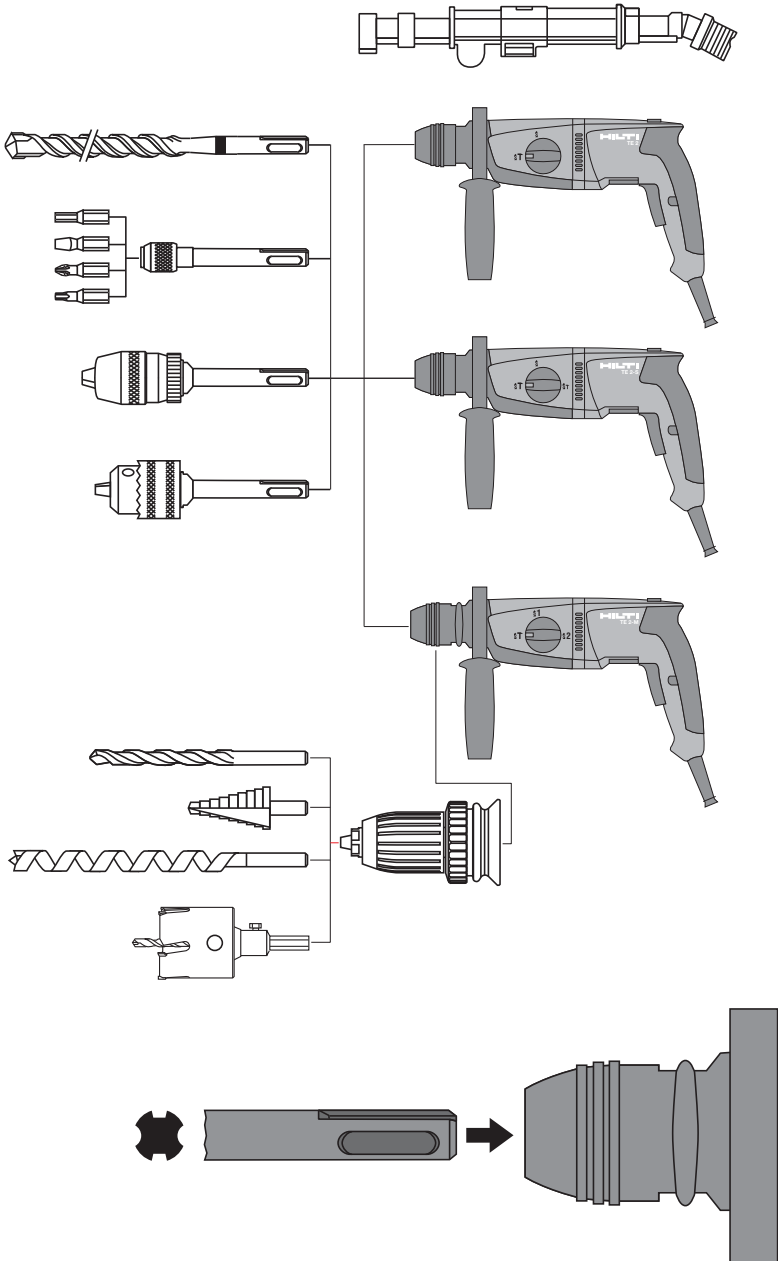

7 TE2 / TE2-E

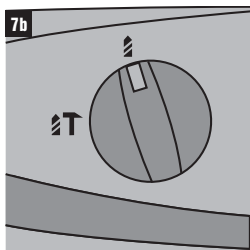
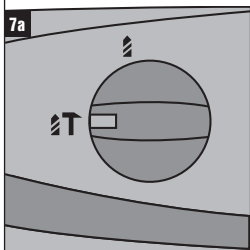

7 TE2-S

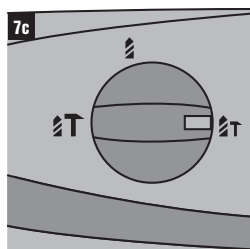
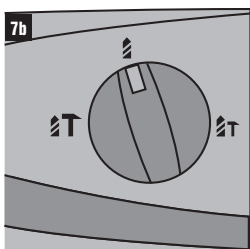
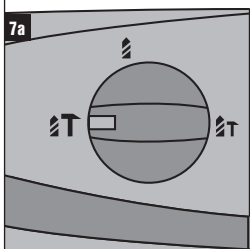

7 TE2-M

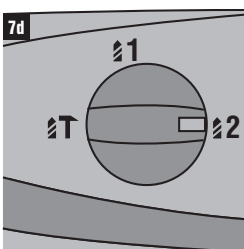
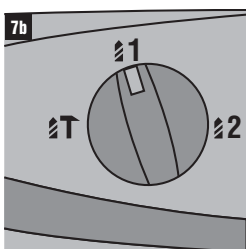
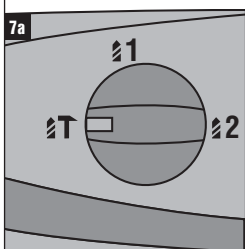

8

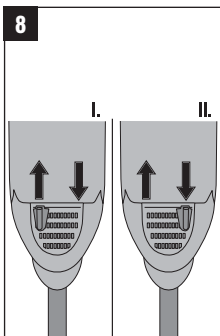

9

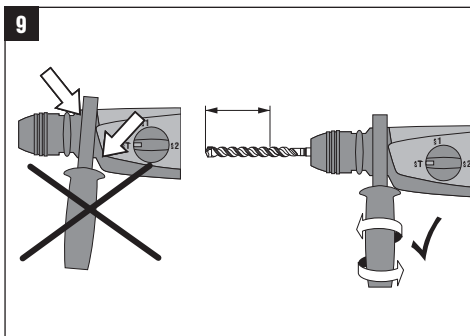

10

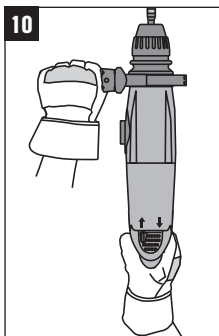

ORIGINAL OPERATING INSTRUCTIONS

TE 2/TE 2-E/TE 2-S/TE 2-M Rotary Hammer

en

It is essential that the operating instructions are read before the tool is operated for the first time.

Always keep these operating instructions together with the tool.

Ensure that the operating instructions are with the tool when it is given to other persons.

Operating controls 1

- 1 Chuck release ring (TE 2-M)
- 2 Function selector switch
- 3 Control switch
- 4 Forwards / reverse switch (TE 2 / TE 2-S / TE 2-M)
- 5 Lockbutton

Component parts 1

- 6 Dust shield
- 7 Chuck
- 8 Side handle
- 9 Type plate

Contents	Page
Safety notices and their meaning	1
Description	2
Technical data	3
Safety rules	4
Before use	6
Operation	6
Drilling	6
Forwards/reverse rotation	7
Insert tools and accessories	7
Care and maintenance	7
Disposal	8
Manufacturer's warranty – tools	8
Troubleshooting	9
Declaration of conformity (original)	9

Safety notices and their meaning

-DANGER-

Draws attention to imminent danger that will lead to serious bodily injury or fatality.

-WARNING-

Draws attention to a potentially dangerous situation that could lead to serious personal injury or fatality.

-CAUTION-

Draws attention to a potentially dangerous situation that could lead to slight personal injury or damage to the equipment or other property.

-NOTE-

Draws attention to an instruction or other useful information.

Pictograms

Warning signs



General warning



Warning: electricity



Warning: hot surface

Obligation signs



Wear eye protection



Wear a safety helmet



Wear ear protection



Wear safety gloves



Wear breathing protection

Symbols



Read the operating instructions before use.



Return waste material for recycling.

A

Amps

V

Volts

W

Watts

Hz

Hertz

/min

Revolutions per minute

~

Alternating current

n₀

Nominal speed under no load

∅

Diameter

1 The numbers refer to the illustrations. The illustrations can be found on the fold-out cover pages. Keep these pages open while you read the operating instructions. In these operating instructions, the power tool to which these operating instructions apply is referred to as “the tool”.

Description

The TE 2 / TE 2-E / TE 2-S / TE 2-M is an electrically powered rotary hammer with pneumatic hammering mechanism designed for professional use.

The following items are supplied: power tool, (quick-release chuck TE 2-M), operating instructions, grease (except TE 2-E), toolbox, side handle, cleaning cloth, Depth gauge.



The following conditions must always be observed when the tool is in use:

- The tool must be connected to an alternating current electric supply in compliance with the information given on the type plate.
- The tool is for hand-held use only.
- The tool must not be used in places where the surrounding conditions may present a risk of explosion.
- Changes or modifications to the tool are not permissible.
- To avoid the risk of injury, use only the genuine Hilti

accessories and additional equipment specified for use with this tool.

- Observe the information printed in the operating instructions concerning operation, care and maintenance. The tool and its ancillary equipment may present hazards when used incorrectly by untrained personnel or when used not as directed.
- The tool is intended for professional use. The tool may be operated, serviced and repaired only by authorized, trained personnel. This personnel must be informed of any special hazards that may be encountered.

Main features of the tool

- Class II electrical protection (double insulated)
- Mechanical torque-limiting clutch
- Grip and side handle with vibration absorption
- TE-C chuck
- TE-C insert tool system
- Variable speed switch
- Rotary-only drilling mode
- Gearing and hammering mechanism with permanent grease lubrication
- Pivotable side handle (360°)
- Mechanical depth gauge
- Interface for quick-release chuck (TE 2-M)
- Precision hammering action (TE 2-S)
- High spindle speed without hammering action (TE 2-M)
- Lockbutton for sustained operation

Right of technical changes reserved

The tool is designed for the following uses:

Use	Required insert tools	Diameter range
TE 2 / TE 2-E / TE 2-S / TE 2-M: Hammer drilling in concrete, masonry and natural stone	Drill bits with TE-C connection end – Short hammer drill bits – Long hammer drill bits	Drilling in concrete: Anchor holes of 4–22 mm dia. Through holes of 4–22 mm dia.
TE 2-S: Drilling with precision hammering action in perforated brick, tiles and marble	Drill bits with TE-C connection end – TE-C hammer drill bits – Thin-barrel core bits	Drilling in brittle materials: Anchor holes of 4–22 mm dia. Cutting sockets of 25–68 mm dia.
TE 2 / TE 2-E / TE 2-S: Drilling in wood, drywall panels and metal	Quick-release chuck with TE-C adaptor for insert tools with cylindrical shank or hexagonal shank for rotary-only drilling Wood drill bits Metal drill bits Hole saws	4–20 mm dia. 3–13 mm dia. 25–68 mm dia.
TE 2-M: Drilling in wood, drywall panels, tiles and metal	Interchangeable quick-release chuck for insert tools with cylindrical shank or hexagonal shank for rotary-only drilling: Wood drill bits Metal/stepped drill bits Hole saws	4–10 mm dia. in 2nd gear 10–20 mm dia. in 1st gear 3– 8 mm dia. in 2nd gear 8–13 mm dia. in 1st gear 25–68 mm dia. in 1st gear

Technical data

Rated power	650 W
Nominal voltage *	100 V 110 V 120 V 220 V 230 V 240 V
Nominal current input *	6.9 A 6.5 A 6.5 A 3.1 A 3.0 A 2.9 A
Mains frequency	50–60 Hz
Weight of tool without side handle	2.4 kg (TE2 / TE2-S / TE2-E) 2.7 kg (TE2-M)
Weight as per EPTA-Procedure 01/2003	2.7 kg (TE2 / TE2-S / TE2-E) 2.9 kg (TE2-M)
Dimensions (l×h×w)	352×203×89 mm (TE2 / TE2-E / TE2-S) 360×203×89 mm (TE2-M)
Minimum distance between wall and hole drilled	34 mm
Speed	0– 930 /min. (hammer drilling) 0–1200 /min (in 1st gear TE2 / TE2-E / TE2-S / TE2-M) 0–2500 /min (in 2nd gear TE2-M)
Hammering speed:	
Precision hammering action	0–2600 /min (TE2-S)
Full hammering action	0–4600 /min (TE2 / TE2-E / TE2-S / TE2-M)
Single impact energy Nm (J):	
Precision hammering action	0.6 Nm (TE2-S)
Full hammering action	1.8 Nm (TE2 / TE2-E / TE2-S / TE2-M)
Typical drilling performance in medium-hard B35 concrete	8 mm dia.: 550 mm/min 10 mm dia.: 500 mm/min 12 mm dia.: 400 mm/min

-NOTE-

The vibration emission level given in this information sheet has been measured in accordance with a standardised test given in EN 60745 and may be used to compare one tool with another. It may be used for a preliminary assessment of exposure. The declared vibration emission level represents the main applications of the tool. However if the tool is used for different applications, with different accessories or poorly maintained, the vibration emission may differ. This may significantly increase the exposure level over the total working period. An estimation of the level of exposure to vibration should also take into account the times when the tool is switched off or when it is running but not actually doing the job. This may significantly reduce the exposure level over the total working period. Identify additional safety measures to protect the operator from the effects of vibration such as: maintain the tool and the accessories, keep the hands warm, organisation of work patterns.

Noise and vibration information (measured in accordance with EN 60745-2-6):

Typical A-weighted sound power level (L _{WA}):	102 dB (A)
Typical A-weighted emission sound power level (L _{pA}):	91dB (A)
For the given sound power level as per EN 60745, the tolerance is	3 dB

Wear ear protection!

Triaxial vibration value (vibration vector sum) measured in accordance with EN 60745-2-1	
Drilling in metal, (a _{h, D})	2.8 m/s ²
measured in accordance with EN 60745-2-6	
Hammer drilling in concrete, (a _{h, HD})	13.5 m/s ²
Uncertainty (K) for triaxial vibration value	1.5 m/s ²

* The tool is offered in different versions for various mains voltages. Please refer to the information on the type plate for the nominal voltage and nominal current input of your tool.

Safety rules

1. General power tool safety warnings



WARNING! Read all safety warnings and all instructions. Failure to follow the warnings and instructions may result in electric shock, fire and/or serious injury. **Save all warnings and instructions for future reference.** The term "power tool" in the warnings refers to your mains-operated (corded) power tool or battery-operated (cordless) power tool.

1.1 Work area safety

- Keep work area clean and well lit.** Cluttered or dark areas invite accidents.
- Do not operate power tools in explosive atmospheres, such as in the presence of flammable liquids, gases or dust.** Power tools create sparks which may ignite the dust or fumes.
- Keep children and bystanders away while operating a power tool.** Distractions can cause you to lose control.

1.2 Electrical safety

- Power tool plugs must match the outlet. Never modify the plug in any way. Do not use any adapter plugs with earthed (grounded) power tools.** Unmodified plugs and matching outlets will reduce risk of electric shock.
- Avoid body contact with earthed or grounded surfaces, such as pipes, radiators, ranges and refrigerators.** There is an increased risk of electric shock if your body is earthed or grounded.
- Do not expose power tools to rain or wet conditions.** Water entering a power tool will increase the risk of electric shock.
- Do not abuse the cord. Never use the cord for carrying, pulling or unplugging the power tool. Keep cord away from heat, oil, sharp edges or moving parts.** Damaged or entangled cords increase the risk of electric shock.
- When operating a power tool outdoors, use an extension cord suitable for outdoor use.** Use of a cord suitable for outdoor use reduces the risk of electric shock.
- If operating a power tool in a damp location is unavoidable, use a residual current device (RCD) protected supply.** Use of an RCD reduces the risk of electric shock.

1.3 Personal safety

- Stay alert, watch what you are doing and use common sense when operating a power tool. Do not use a power tool while you are tired or under the influence of drugs, alcohol or medication.** A moment of inattention while operating power tools may result in serious personal injury.
- Use personal protective equipment. Always wear eye protection.** Protective equipment such as dust mask, non-skid safety shoes, hard hat, or hearing protection used for appropriate conditions will reduce personal injuries.

- Prevent unintentional starting. Ensure the switch is in the off-position before connecting to power source and/or battery pack, picking up or carrying the tool.** Carrying power tools with your finger on the switch or energising power tools that have the switch on invites accidents.
- Remove any adjusting key or wrench before turning the power tool on.** A wrench or a key left attached to a rotating part of the power tool may result in personal injury.
- Do not overreach. Keep proper footing and balance at all times.** This enables better control of the power tool in unexpected situations.
- Dress properly. Do not wear loose clothing or jewellery. Keep your hair, clothing and gloves away from moving parts.** Loose clothes, jewellery or long hair can be caught in moving parts.
- If devices are provided for the connection of dust extraction and collection facilities, ensure these are connected and properly used.** Use of dust collection can reduce dust-related hazards.

1.4 Power tool use and care

- Do not force the power tool. Use the correct power tool for your application.** The correct power tool will do the job better and safer at the rate for which it was designed.
- Do not use the power tool if the switch does not turn it on and off.** Any power tool that cannot be controlled with the switch is dangerous and must be repaired.
- Disconnect the plug from the power source and/or the battery pack from the power tool before making any adjustments, changing accessories, or storing power tools.** Such preventive safety measures reduce the risk of starting the power tool accidentally.
- Store idle power tools out of the reach of children and do not allow persons unfamiliar with the power tool or these instructions to operate the power tool.** Power tools are dangerous in the hands of untrained users.
- Maintain power tools. Check for misalignment or binding of moving parts, breakage of parts and any other condition that may affect the power tool's operation. If damaged, have the power tool repaired before use.** Many accidents are caused by poorly maintained power tools.
- Keep cutting tools sharp and clean.** Properly maintained cutting tools with sharp cutting edges are less likely to bind and are easier to control.
- Use the power tool, accessories and tool bits etc. in accordance with these instructions, taking into account the working conditions and the work to be performed.** Use of the power tool for operations different from those intended could result in a hazardous situation.

1.5 Service

- Have your power tool serviced by a qualified repair person using only identical replacement parts.** This will ensure that the safety of the power tool is maintained.

2. Hammer safety warnings

- a) **Wear ear protectors.** Exposure to noise can cause hearing loss.
- b) **Use auxiliary handle(s), if supplied with the tool.** Loss of control can cause personal injury.
- c) **Hold power tool by insulated gripping surfaces, when performing an operation where the cutting accessory may contact hidden wiring or its own cord.** Cutting accessory contacting a "live" wire may make exposed metal parts of the power tool "live" and could give the operator an electric shock.

3. Additional safety rules

3.1 Personal safety

- a) **Always hold the tool with both hands on the grips provided. Keep the grips dry, clean and free from oil and grease.**
- b) **Exercise your fingers during pauses between work to improve the blood circulation in your fingers.**
- c) **Avoid contact with rotating parts. Switch the tool on only once it has been brought into the working position close to the workpiece.**
- d) **Breathing protection must be worn when the tool is used without a dust removal system for work that creates dust.**
- e) **To avoid tripping and falling when working, always lead the supply cord, extension cord and dust extraction hose away to the rear.**
- f) **When drilling or chiseling through-holes, check that no person is present in the danger area immediately behind the work surface.**
- g) **Hold tool by insulated gripping surfaces when performing an operation where the cutting tool may contact hidden wiring or its own cord. Contact with a "live" wire will make exposed metal parts of the tool "live" and shock the operator.**
- h) **Children must be instructed not to play with the tool.**
- i) **The tool is not intended for use by children, by debilitated persons or those who have received no instruction or training.**
- j) *Dust from material such as paint containing lead, some wood species, minerals and metal may be harmful. Contact with or inhalation of the dust may cause allergic reactions and/or respiratory diseases to the operator or bystanders. Certain kinds of dust are classified as carcinogenic such as oak and beech dust especially in conjunction with additives for wood conditioning (chromate, wood preservative). Material containing asbestos must only be treated by specialists. Where the use of a dust extraction device is possible it shall be used. To achieve a high level of dust collection, use a suitable vacuum cleaner of the type recommended by Hilti for wood dust and/or mineral dust together with this tool. Ensure that the workplace is well ventilated. The use of a dust mask of filter class P2 is recommended. Follow national requirements for the materials you want to work with.*

3.2 Power tool use and care

- a) **Secure the workpiece. Use clamps or a vice to hold**

the workpiece in place. *The workpiece is thus held more securely than by hand and both hands remain free to operate the tool.*

- b) **Ensure that the insert tools used are equipped with the appropriate connection end system and that they are properly fitted and secured in the chuck.**
- c) **In the event of a power failure, switch the tool off and unplug the supply cord.** *This prevents inadvertent starting when the power returns.*
- d) **In the event of an interruption in the electric supply and before laying the tool down each time, check that the lockbutton for sustained operation has been released. Release the lockbutton if necessary.** *Failure to observe this point could cause the tool to start unexpectedly when the power returns.*
- e) **Do not apply an excessive quantity of grease to the drill bit connection end.** *Excess grease may otherwise be forced out of the chuck during operation.*

3.3 Electrical safety

- a) **Before beginning work, check the working area (e.g. with a metal detector) to ensure that no concealed electric cables or gas and water pipes are present.** *External metal parts of the tool may become live if, for example, an electric cable is damaged inadvertently. This presents a serious risk of electric shock.*
- b) **Check the condition of the supply cord and its plug connections and have it replaced by a qualified electrician if damage is found. Check the condition of the extension cord and replace it if damage is found. Do not touch the supply in the event of it suffering damage while working. Disconnect the supply cord plug from the socket.** *Damaged supply cords and extension cords present a risk of electric shock.*
- c) **Dirty or dusty electric tools should thus be checked at a Hilti service center at regular intervals, especially if used frequently for working on conductive materials.** *Dust (especially dust from conductive materials) or dampness adhering to the surface of the tool may, under unfavorable conditions, present a risk of electric shock.*

3.4 Work area

- a) **Ensure that the workplace is well lit.**
- b) **Ensure that the workplace is well ventilated.** *Poorly ventilated workplaces may be injurious to the health due to exposure to dust.*

3.5 Personal protective equipment

The user and any other persons in the vicinity must wear suitable eye protection, a hard hat, ear protection and protective gloves when the tool is in use. Breathing protection must be worn if no dust removal system is used.



Wear eye protection



Wear a hard hat



Wear ear protection



Wear protective gloves



Wear breathing protection

Before use



en It is essential that the safety precautions printed in these operating instructions are read and observed.

Fitting the side handle

1. Unplug the tool from the mains socket.
2. Release the side handle clamping band by turning the handle in a counter-clockwise direction.
3. Fit the side handle clamping band over the chuck and onto the cylindrical section at the front end of the tool.
4. Pivot the side handle into the desired position.
5. Tighten the side handle securely to prevent inadvertent movement.



Check that the side handle is seated securely.



The supply voltage must correspond to the information on the type plate.



If extension cords are used: Only extension cords of a type approved for the intended use and of adequate cross section may be used. Failure to observe this point may result in reduced performance of the tool and overheating of the cord. Damaged extension cords must be replaced.

Use only insert tools with TE-C connection end.

Don't exert excessive pressure on the tool. This will not increase its hammering power.

At low temperatures: The tool requires to reach a minimum operating temperature before the hammering mechanism begins to operate. Switch on the tool and position the tip of the drill bit on the work surface. While the tool is running, apply light pressure briefly and repeatedly until the hammering mechanism begins to operate.

Operation



CAUTION: In the event of the drill bit sticking, the tool will pivot about its own axis.

Always use the tool with the side handle fitted and hold it securely with both hands applying an opposing torque

so that the clutch releases in the event of the drill bit sticking.

Use a vice or clamp to secure loose workpieces.

Fitting the insert tool 4 5a

1. Unplug the supply cord from the mains socket.
2. Check that the connection end of the insert tool is clean and lightly greased. Clean it and grease it if necessary.
3. Check that the sealing lip of the dust shield is clean and in good condition. Clean the dust shield if necessary or replace it if the sealing lip is damaged.
4. Push the connection end of the insert tool into the chuck and, while applying slight pressure, rotate the insert tool until it engages in the guide grooves.
5. Push the insert tool further into the chuck until it is heard to engage.
6. Check that the insert tool has engaged correctly (pull by hand).

Removing the insert tool 5b



-CAUTION-

– The insert tool may become hot during use. There is a risk of burning the hands. Wear protective gloves when changing insert tools.

1. Unplug the supply cord from the mains socket.
2. Open the chuck by pulling back the locking sleeve.
3. Pull the insert tool out of the chuck.

Drilling

Hammer drilling (TE2 / TE2-E / TE2-S / TE2-M) / precision hammering action (TE2-S)

1. Insert the drill bit into the chuck.
2. Turn the function selection switch to the hammer drilling position (⚡) until the gearing is engaged 7a.

Rotate the chuck spindle slightly if necessary. Check that forwards rotation is selected 8 (I.).

3. Use of the precision hammering action (⚡) is advantageous when drilling in brittle materials (e.g. tiles, marble, perforated brick). This will improve the quality of the holes drilled 7a.
4. Connect the supply cord to the power supply.
5. Pivot the side handle, with or without the depth gauge, to the desired angle and tighten the handle to lock it in this position. Check that the side handle is seated and attached securely 9.
6. Bring the tip of the drill bit into contact with the work surface at the position where the hole is to be drilled and press the control switch slowly. Drill at low speed until the drill bit centres itself in the hole.
7. Press the control switch fully and continue drilling at full power.

Rotary-only drilling (without hammering action) (TE2 / TE2-E / TE2-S)

Turn the function selection switch to the drilling position (2) **74**. When the switch is in this position, only the rotary movement is transmitted to the TE-C insert tool or chuck adaptor for insert tools with cylindrical shanks.

Rotary-only drilling (without hammering action) (TE2-M)

Turn the function selection switch to the 1st gear or 2nd gear drilling position **74** **74**. When the switch is in these positions, only the rotary movement is transmitted to the TE-C insert tool or quick-release chuck.

Use of a high spindle speed can be advantageous when drilling in metal or wood. For higher drilling speed, the function selection switch must be engaged in the 2nd gear position (22) **74**.

Changing the chuck (TE2-M)

Pull the chuck release ring towards the front and remove the chuck completely. When fitting the chuck, pull the release ring towards the front and hold it in this position. Push the chuck onto the guide tube as far as it will go and release the ring. Rotate the chuck until it engages and the ring snaps back into its original position **3**. The TE-C interchangeable chuck or quick-release interchangeable chuck may be fitted to the TE2-M with chuck interface **2**.

Drilling using the depth gauge

We recommend the use of the depth gauge for drilling holes accurately to the desired depth. The depth gauge is integrated in the side handle, which can be pivoted and locked in position. Release the side handle (turn counter-clockwise), set the depth gauge to the desired drilling depth and tighten the side handle (turn clockwise) **9**.

Forwards / reverse rotation (TE2 / TE2-S / TE2-M)

For screwdriving, the desired direction of rotation can be selected simply by moving the switch **8**.

For forwards rotation, select position (↑) and for reverse rotation, select position (↓).

When the tool is operated in reverse rotation, the function selection switch **7** should be engaged in the position for drilling without hammering action (2 / 1st gear). For drilling, always ensure that forwards rotation (↑) is selected.

Insert tools and accessories

Use only insert tools with TE-C connection end or straight shank bits with quick release chuck or adaptor **6**.

Hilti power tools have been designed to work optimally as a system together with Hilti insert tools. Accordingly, highest performance and longest life expectancy can be achieved when you use this power tool with Hilti insert tools. A comprehensive programme of insert tools and accessories is available for the TE-C system **6**. Details of the entire programme can be found in the current Hilti product catalogue.

Should you require insert tools not included in the standard programme, please contact the Hilti customer service department or your Hilti sales representative. Hilti offers a comprehensive range of special insert tools in professional quality.



Check your insert tools at regular intervals and replace them in good time. A damaged or badly worn connection end may result in damage to the power tool. Drill bits with chipped or broken carbide tips may no longer drill holes of the specified diameter, thus influencing their suitability for anchor fastenings.

Please observe the instructions on care and maintenance of your insert tools given in the following section.

Dust removal (TE DRS-S) **6**

A DRS extraction head can be attached to the side handle / depth gauge. An industrial vacuum cleaner is used to remove drilling dust and fragments.

Care and maintenance

-CAUTION-

Disconnect the supply cord plug from the power outlet.

Care of insert tools

Clean off dirt and dust deposits adhering to the insert tools and protect them from corrosion by wiping the insert tools from time to time with an oil-soaked rag.

Care of the power tool

-CAUTION-

Keep the power tool, especially its grip surfaces, clean and free from oil and grease. Do not use cleaning agents which contain silicone.

The outer casing of the power tool is made from impact-resistant plastic. Sections of the grip are made from a synthetic rubber material.

Never operate the power tool when the ventilation slots are blocked. Clean the ventilation slots carefully using a dry brush. Do not permit foreign objects to enter the interior of the power tool. Clean the outside of the pow-

er tool at regular intervals with a slightly damp cloth. Do not use a spray, steam pressure cleaning equipment or running water for cleaning. This may negatively affect the electrical safety of the power tool.

en

Cleaning or replacing the dust shield

Clean the dust shield on the chuck with a dry, clean cloth at regular intervals. Clean the sealing lip by wiping it carefully and then grease it again lightly with Hilti grease. It is essential that the dust shield is replaced if the sealing lip is found to be damaged. Push the tip of a screwdriver under the edge of the dust shield and prise it out toward the front. Clean the area of the chuck in contact with dust shield and then fit a new dust shield. Press it in firmly until it engages.

Maintenance

-WARNING-

Repairs to the electrical section of the power tool may be carried out only by trained electrical specialists.

Check all external parts of the power tool for damage at regular intervals and check that all controls operate faultlessly. Do not operate the power tool if parts are damaged or when the controls do not function faultlessly. If necessary, the power tool should be repaired by Hilti Service.

Checking the power tool after care and maintenance

After carrying out care and maintenance work on the power tool, check that all protective and safety devices are fitted and that they function faultlessly.

Disposal



Return waste material for recycling

Most of the materials from which Hilti power tools are manufactured can be recycled. The materials must be correctly separated before they can be recycled. In many countries, Hilti has already made arrangements for taking back your old electric tools for recycling. Please ask your Hilti customer service department or Hilti sales representative for further information.



Only for EU countries

Disposal of electric tools together with household waste is not permissible!

In observance of European Directive on waste electrical and electronic equipment and its implementation in accordance with national law, electric tools that have reached the end of their life must be collected separately and returned to an environmentally compatible recycling facility.

Manufacturer's warranty – tools

Hilti warrants that the tool supplied is free of defects in material and workmanship. This warranty is valid so long as the tool is operated and handled correctly, cleaned and serviced properly and in accordance with the Hilti Operating Instructions, and the technical system is maintained. This means that only original Hilti consumables, components and spare parts may be used in the tool.

This warranty provides the free-of-charge repair or replacement of defective parts only over the entire lifespan of the tool. Parts requiring repair or replacement as a result of normal wear and tear are not covered by this warranty.

Additional claims are excluded, unless stringent national rules prohibit such exclusion. In particular,

Hilti is not obligated for direct, indirect, incidental or consequential damages, losses or expenses in connection with, or by reason of, the use of, or inability to use the tool for any purpose. Implied warranties of merchantability or fitness for a particular purpose are specifically excluded.

For repair or replacement, send tool or related parts immediately upon discovery of the defect to the address of the local Hilti marketing organization provided.

This constitutes Hilti's entire obligation with regard to warranty and supersedes all prior or contemporaneous comments and oral or written agreements concerning warranties.

Troubleshooting

Symptom	Possible cause	Possible solution
The tool doesn't start	Fault in the electric power supply	Plug in another electric tool and check whether it starts
	Defective supply cord or plug	Have it checked by an electrical specialist and replace if necessary
	Switch defective	Have it checked by an electrical specialist and replace if necessary
No hammering action	The tool is too cold	Allow tool to reach the minimum operating temperature See section "Before use"
	Function selection switch set to rotary drilling	Set function selection switch to hammer drilling
Tool doesn't produce full power	Cross-section of the extension cord is inadequate	Use an extension cord of adequate cross-sectional area. See section "Before use"
	Control switch is not pressed fully	Press the control switch as far as it will go
	Function selection switch set to precision hammering action	Set function selection switch to hammer drilling
	Forwards / reverse switch set to reserve when drilling	Set forwards / reverse switch to forwards
Drill bit cannot be released	Chuck not opened fully	Pull the chuck locking sleeve back as far as it will go and remove the insert tool

en

EC declaration of conformity (original)

Description: Rotary Hammer
 Designation: TE2 / TE2-E / TE2-S / TE2-M
 Year of design: 2005

We declare, under our sole responsibility, that this product complies with the following directives and standards: 2004/108/EC, 2006/42/EC, EN 60745-1, EN 60745-2-6, EN 12100, 2011/65/EU

**Hilti Corporation, Feldkircherstrasse 100,
 FL-9494 Schaan**



Paolo Luccini
 Head of BA
 Quality and Process Management
 Business Area
 Electric Tools & Accessories
 01/2012

Jan Doongaji
 Senior Vice President
 BU Drilling & Demolition

01/2012

Technical documentation filed at:

Hilti Entwicklungsgesellschaft mbH
 Zulassung Elektrowerkzeuge
 Hiltistrasse 6
 86916 Kaufering
 Deutschland



Hilti Corporation

LI-9494 Schaan
Tel.: +423 / 234 21 11
Fax: +423 / 234 29 65
www.hilti.com

Hilti = registered trademark of Hilti Corp., Schaan
W 2740 | 0514 | 10-Pos. 8 | 1
Printed in China © 2014
Right of technical and programme changes reserved S. E. & O.

2059548 / A3



2059548