

HILTI

SID/SIW 14-A/22-A

Operating instructions

Mode d'emploi

Brugsanvisning

Bruksanvisning

Bruksanvisning

Käyttöohje

Инструкция по эксплуатации

Kullanma Talimatı

دليل الاستعمال

Lietošanas pamācība

Instrukcija

Kasutusjuhend

ІНСТРУКЦІЯ З ЕКСПЛУАТАЦІЇ

Пайдалану бойынша басшылық

取扱説明書

사용설명서

操作説明書

操作说明书

en

fr

da

sv

no

fi

ru

tr

ar

lv

lt

et

uk

kk

ja

ko

zh

cn



CE

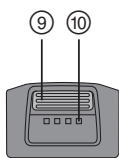
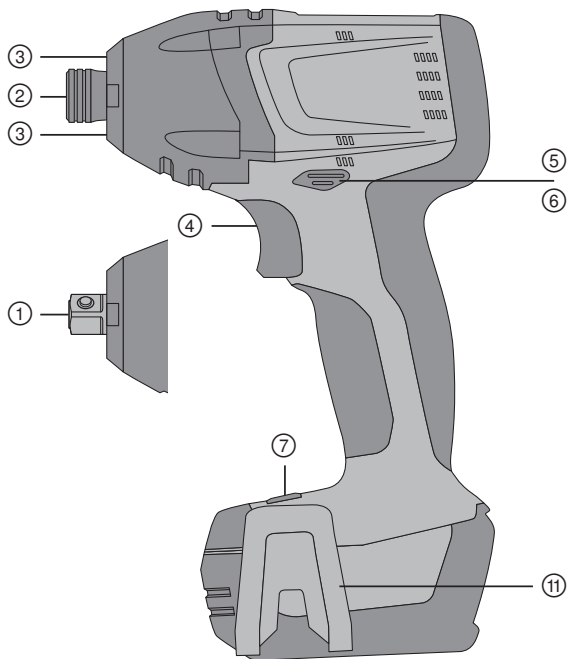

B14 1.6 Ah

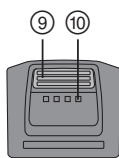

B14 3.3 Ah

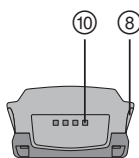

B22 1.6 Ah

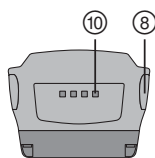

**B22 2.6 Ah
B22 3.3 Ah**

2

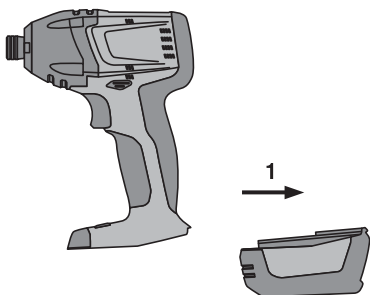

3

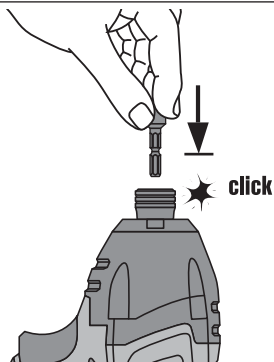

4

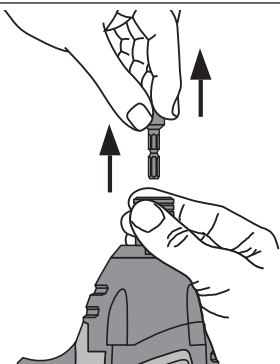

5

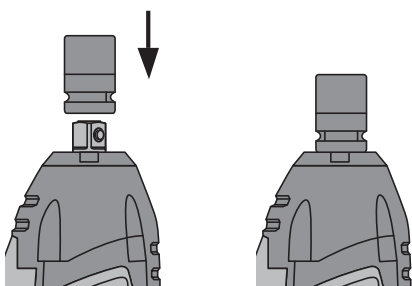

6

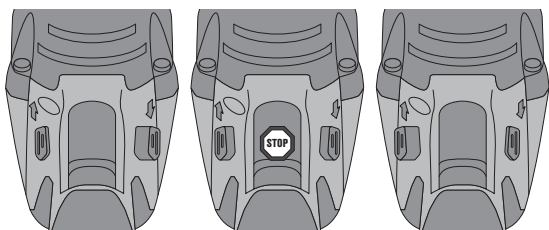

7

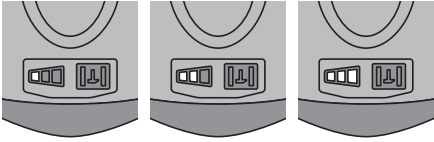

8

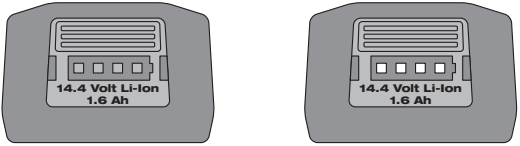

9

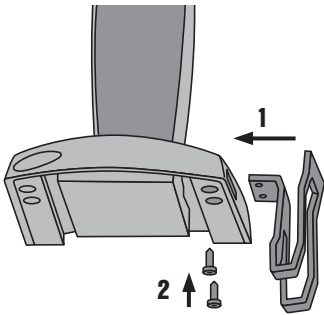

ORIGINAL OPERATING INSTRUCTIONS

SID 14-A / SID 22-A / SIW 14-A / SIW 22-A cordless impact screwdriver / wrench

en

It is essential that the operating instructions are read before the power tool is operated for the first time.

Always keep these operating instructions together with the power tool.

Ensure that the operating instructions are with the power tool when it is given to other persons.

Contents

1	General information	1
2	Description	2
3	Insert tools, accessories	3
4	Technical data	3
5	Safety instructions	6
6	Before use	9
7	Operation	10
8	Care and maintenance	12
9	Troubleshooting	13
10	Disposal	13
11	Manufacturer's warranty - tools	14
12	EC declaration of conformity (original)	14

1 These numbers refer to the corresponding illustrations. The illustrations can be found on the fold-out cover pages. Keep these pages open while studying the operating instructions.

In these operating instructions, the designation "the power tool" always refers to the SIW 14-A, SIW 22-A, SID 14-A or SID 22-A cordless impact wrench / screwdriver with battery fitted.

Operating controls and parts **1**

- ① SIW square drive
- ② SID hex. socket drive
- ③ Light
- ④ Control switch (with electronic speed control)
- ⑤ Forward / reverse switch
- ⑥ Motor brake
- ⑦ Torque selector switch
- ⑧ SID/W 22-A battery release buttons
- ⑨ SID/W 14-A battery release button
- ⑩ Charge status and fault display (Li-ion battery)
- ⑪ Belt hook (optional)

1 General information

1.1 Safety notices and their meaning

DANGER

Draws attention to imminent danger that will lead to serious bodily injury or fatality.

WARNING

Draws attention to a potentially dangerous situation that could lead to serious personal injury or fatality.

CAUTION

Draws attention to a potentially dangerous situation that could lead to slight personal injury or damage to the equipment or other property.

NOTE

Draws attention to an instruction or other useful information.

1.2 Explanation of the pictograms and other information

Warning signs



General warning



Warning:
electricity



Warning: caustic
substances

Obligation signs



Wear eye
protection



Wear a hard hat



Wear ear
protection



Wear protective
gloves



Wear breathing
protection

Symbols



Read the
operating
instructions
before use



Return waste
material for
recycling.



Volts



Direct current

n_0

Rated speed
under no load

/min

Revolutions per
minute

Location of identification data on the power tool

The type designation can be found on the type identification plate and the serial number on the side of the motor housing. Make a note of this data in your operating instructions and always refer to it when making an enquiry to your Hilti representative or service department.

Type:

Generation: 01

Serial no.:

2 Description

2.1 Use of the product as directed

The SID 14-A, SIW 14-A, SID 22-A and SIW 22-A are hand-held cordless impact screwdrivers/wrenches. They are designed for driving and removing screws in wood, metal, masonry and concrete and for tightening and releasing nuts and bolts.

Working on materials hazardous to the health (e.g. asbestos) is not permissible.

Do not use the battery as a power source for other unspecified appliances.

Modification of the power tool or tampering with its parts is not permissible.

To avoid the risk of injury, use only genuine Hilti accessories and insert tools.

The power tool should not be used for applications that require a precise torque. For applications that require a precise torque or where only a special limited torque is permitted, there is a risk of over-tightening and damage to the screw or workpiece. For these types of application, use a tool with a predefined torque setting to prevent over-tightening.

Observe the information printed in the operating instructions concerning operation, care and maintenance.

The power tool is designed for professional use and may be operated, serviced and maintained only by trained, authorized

personnel. This personnel must be informed of any special hazards that may be encountered. The power tool and its ancillary equipment may present hazards when used incorrectly by untrained personnel or when used not as directed.

The working environment may be as follows: construction site, workshop, renovation, conversion or new construction.

Nationally applicable industrial safety regulations must be observed.

en

2.2 The items supplied include (toolbox versions):

- 1 Power tool
- 1 Operating instructions
- 1 Hilti toolbox

2.3 The items supplied include (cardboard box versions):

- 1 Power tool
- 1 Operating instructions

2.4 Additional items required for operating the tool

B 22/1.6 Li-Ion, B 22/2.6 Li-Ion, B 22/3.3 Li-Ion, B 14/1.6 Li-Ion or B 14/3.3 Li-Ion battery with C4/36-90, C4/36-350, C 4/36, C 4/36-ACS or C 4/36-ACS TPS charger.

2.5 Li-ion battery charge status

LEDs light constantly	LEDs blink	Charge status C
LED 1, 2, 3, 4	-	$C \geq 75 \%$
LED 1, 2, 3	-	$50 \% \leq C < 75 \%$
LED 1, 2	-	$25 \% \leq C < 50 \%$
LED 1	-	$10 \% \leq C < 25 \%$
-	LED 1	$C < 10 \%$

3 Insert tools, accessories

Designation	Short designation	Description
Bit holder		S-BH 50
Charger for Li-ion batteries	C 4/36-ACS	
Charger for Li-ion batteries	C 4/36	
Charger for Li-ion batteries	C 4/36-90	
Charger for Li-ion batteries	C 4/36-350	
Battery	B 14/3.3, B 14/1.6 Li-Ion	
Battery	B 22/2.6, B 22/1.6 Li-Ion	
Battery	B 22/3.3 Li-Ion	
Belt hook		

Designation	Description
Bits	Hex. bit, bit adapter, drill bits with hex. shank
Sockets	Impact wrench sockets

4 Technical data

Right of technical changes reserved.

Power tool	SID 14-A	SIW 14-A
Rated voltage	14.4 V	14.4 V
Weight (including battery and chuck) in accordance with EPTA procedure 01/2003	1.3 kg	1.3 kg

Power tool	SID 14-A	SIW 14-A
Dimensions (L x W x H)	151 mm x 81 mm x 228 mm	154 mm x 81 mm x 228 mm
Rated no-load running speed, pos. I	0... 1,000/min	0... 1,000/min
Rated no-load running speed, pos. II	0... 1,500/min	0... 1,500/min
Rated no-load running speed, pos. III	0... 2,500/min	0... 2,300/min
Impact speed	Max. 3,100/min	Max. 3,400/min
Speed adjustment	Three settings	Three settings
Standard screws	M8 - M16	M8 - M16
High-strength screws	M6 - M12	M6 - M12
Chuck	1/4" hex. socket with locking sleeve	1/2" square drive with ball-notch retention and 3/8" with locking ring
Speed control	Electronic, by way of the control switch	Electronic, by way of the control switch
Forward / reverse	Electronic switch with interlock to prevent switching while running	Electronic switch with interlock to prevent switching while running
Deep discharge protection	Yes	

Power tool	SID 22-A	SIW 22-A
Rated voltage	21.6 V	21.6 V
Weight (including battery and chuck) in accordance with EPTA procedure 01/2003	1.5 kg	1.5 kg
Dimensions (L x W x H)	151 mm x 94 mm x 228 mm	154 mm x 94 mm x 228 mm
Rated no-load running speed, pos. I	0... 1,000/min	0... 1,000/min
Rated no-load running speed, pos. II	0... 1,500/min	0... 1,500/min
Rated no-load running speed, pos. III	0... 2,500/min	0... 2,300/min
Impact speed	Max. 3,450/min	Max. 3,500/min
Speed adjustment	Three settings	Three settings
Standard screws	M8 - M16	M8 - M16
High-strength screws	M6 - M12	M6 - M12
Chuck	1/4" hex. socket with locking sleeve	1/2" square drive with ball-notch retention and 3/8" with locking ring
Speed control	Electronic, by way of the control switch	Electronic, by way of the control switch
Forward / reverse	Electronic switch with interlock to prevent switching while running	Electronic switch with interlock to prevent switching while running
Deep discharge protection	Yes	Yes

NOTE

The torque selector switch can be used to select three torque settings.

Power tool	Position I	Position II	Position III
SID 14-A	50 Nm	100 Nm	150 Nm
SIW 14-A (3/8" square drive)	65 Nm	115 Nm	160 Nm

Power tool	Position I	Position II	Position III
SIW 14-A (½" square drive)	80 Nm	120 Nm	185 Nm
SID 22-A	60 Nm	110 Nm	165 Nm
SIW 22-A (⅜" square drive)	75 Nm	120 Nm	175 Nm
SIW 22-A (½" square drive)	90 Nm	135 Nm	200 Nm

NOTE

The vibration emission level given in this information sheet has been measured in accordance with a standardised test given in EN 60745 and may be used to compare one tool with another. It may be used for a preliminary assessment of exposure. The declared vibration emission level represents the main applications of the tool. However if the tool is used for different applications, with different accessories or poorly maintained, the vibration emission may differ. This may significantly increase the exposure level over the total working period. An estimation of the level of exposure to vibration should also take into account the times when the tool is switched off or when it is running but not actually doing the job. This may significantly reduce the exposure level over the total working period. Identify additional safety measures to protect the operator from the effects of vibration such as: maintain the tool and the accessories, keep the hands warm, organisation of work patterns.

Noise information (measured in accordance with EN 60745-1):

Typical A-weighted sound power level for the SID 14-A and SIW 14-A	94 dB (A)
Typical A-weighted sound power level for the SID 22-A and SIW 22-A	97 dB (A)
Typical A-weighted emission sound power level for the SID 14-A and SIW 14-A	83 dB (A)
Typical A-weighted emission sound power level for the SID 22-A and SIW 22-A	86 dB (A)
Uncertainty for the given sound level	3 dB (A)

Additional information in accordance with EN 60745

Triaxial vibration values (vibration vector sum)	Measured in accordance with EN 60745-2-2
Impact driving of fasteners of maximum size for the tool, SID 22-A and SIW 22-A, a_h	11 m/s ²
Impact driving of fasteners of maximum size for the tool, SID 14-A and SIW 14-A, a_h	7.5 m/s ²
Uncertainty (K)	1.5 m/s ²

Battery	B 22/1.6 Li-Ion	B 22/2.6 Li-Ion	B 22/3.3 Li-Ion
Rated voltage	21.6 V	21.6 V	21.6 V
Battery capacity	1.6 Ah	2.6 Ah	3.3 Ah
Energy content	34.56 Wh	56.16 Wh	71.28 Wh
Weight	0.48 kg	0.78 kg	0.78 kg
Temperature monitoring	Yes	Yes	Yes
Type of cell	Li-Ion	Li-Ion	Li-Ion
No. of cells	6	12	12

Battery	B 14/1.6 Li-Ion	B 14/3.3 Li-Ion
Rated voltage	14.4 V	14.4 V
Battery capacity	1.6 Ah	3.3 Ah

Battery	B 14/1.6 Li-Ion	B 14/3.3 Li-Ion
Energy content	23.04 Wh	47.52 Wh
Weight	0.36 kg	0.58 kg
Temperature monitoring	Yes	Yes
Type of cell	Li-Ion	Li-Ion
No. of cells	4	8

5 Safety instructions

NOTE

The safety rules in section 5.1 contain all general safety rules for power tools which, in accordance with the applicable standards, require to be listed in the operating instructions. Accordingly, some of the rules listed may not be relevant to this tool.

5.1 General power tool safety warnings

a) WARNING

Read all safety warnings and all instructions. Failure to follow the warnings and instructions may result in electric shock, fire and/or serious injury. **Save all warnings and instructions for future reference.** The term “power tool” in the warnings refers to your mains-operated (corded) power tool or battery-operated (cordless) power tool.

5.1.1 Work area safety

- Keep work area clean and well lit.** Cluttered or dark areas invite accidents.
- Do not operate power tools in explosive atmospheres, such as in the presence of flammable liquids, gases or dust.** Power tools create sparks which may ignite the dust or fumes.
- Keep children and bystanders away while operating a power tool.** Distractions can cause you to lose control.

5.1.2 Electrical safety

- Power tool plugs must match the outlet. Never modify the plug in any way. Do not use any adapter plugs with earthed (grounded) power tools.** Unmodified plugs and matching outlets will reduce risk of electric shock.
- Avoid body contact with earthed or grounded surfaces, such as pipes, radiators, ranges and refrigerators.** There is an increased risk of electric shock if your body is earthed or grounded.
- Do not expose power tools to rain or wet conditions.** Water entering a power tool will increase the risk of electric shock.
- Do not abuse the cord. Never use the cord for carrying, pulling or unplugging the power tool. Keep cord away from heat, oil, sharp edges or moving parts.** Damaged or entangled cords increase the risk of electric shock.
- When operating a power tool outdoors, use an extension cord suitable for outdoor use.** Use of a cord suitable for outdoor use reduces the risk of electric shock.
- If operating a power tool in a damp location is unavoidable, use a residual current device (RCD) protected supply.** Use of an RCD reduces the risk of electric shock.

5.1.3 Personal safety

- Stay alert, watch what you are doing and use common sense when operating a power tool. Do not use a power tool while you are tired or under the influence of drugs, alcohol or medication.** A moment of inattention while operating power tools may result in serious personal injury.
- Use personal protective equipment. Always wear eye protection.** Protective equipment such as dust mask, non-skid safety shoes, hard hat, or hearing protection used for appropriate conditions will reduce personal injuries.
- Prevent unintentional starting. Ensure the switch is in the off-position before connecting to power source and/or battery pack, picking up or carrying the tool.** Carrying power tools with your finger on the switch or energising power tools that have the switch on invites accidents.

- d) **Remove any adjusting key or wrench before turning the power tool on.** A wrench or a key left attached to a rotating part of the power tool may result in personal injury.
- e) **Do not overreach. Keep proper footing and balance at all times.** This enables better control of the power tool in unexpected situations.
- f) **Dress properly. Do not wear loose clothing or jewellery. Keep your hair, clothing and gloves away from moving parts.** Loose clothes, jewellery or long hair can be caught in moving parts.
- g) **If devices are provided for the connection of dust extraction and collection facilities, ensure these are connected and properly used.** Use of dust collection can reduce dust-related hazards.

5.1.4 Power tool use and care

- a) **Do not force the power tool. Use the correct power tool for your application.** The correct power tool will do the job better and safer at the rate for which it was designed.
- b) **Do not use the power tool if the switch does not turn it on and off.** Any power tool that cannot be controlled with the switch is dangerous and must be repaired.
- c) **Disconnect the plug from the power source and/or the battery pack from the power tool before making any adjustments, changing accessories, or storing power tools.** Such preventive safety measures reduce the risk of starting the power tool accidentally.
- d) **Store idle power tools out of the reach of children and do not allow persons unfamiliar with the power tool or these instructions to operate the power tool.** Power tools are dangerous in the hands of untrained users.
- e) **Maintain power tools. Check for misalignment or binding of moving parts, breakage of parts and any other condition that may affect the power tool's operation. If damaged, have the power tool repaired before use.** Many accidents are caused by poorly maintained power tools.
- f) **Keep cutting tools sharp and clean.** Properly maintained cutting tools with sharp cutting edges are less likely to bind and are easier to control.
- g) **Use the power tool, accessories and tool bits etc. in accordance with these instructions, taking into account the working conditions and the work to be performed.** Use of the power tool for operations different from those intended could result in a hazardous situation.

5.1.5 Battery tool use and care

- a) **Recharge only with the charger specified by the manufacturer.** A charger that is suitable for one type of battery pack may create a risk of fire when used with another battery pack.
- b) **Use power tools only with specifically designated battery packs.** Use of any other battery packs may create a risk of injury and fire.
- c) **When battery pack is not in use, keep it away from other metal objects, like paper clips, coins, keys, nails, screws or other small metal objects, that can make a connection from one terminal to another.** Shorting the battery terminals together may cause burns or a fire.
- d) **Under abusive conditions, liquid may be ejected from the battery; avoid contact. If contact accidentally occurs, flush with water. If liquid contacts eyes, additionally seek medical help.** Liquid ejected from the battery may cause irritation or burns.

5.1.6 Service

- a) **Have your power tool serviced by a qualified repair person using only identical replacement parts.** This will ensure that the safety of the power tool is maintained.

5.2 Additional safety precautions

5.2.1 Personal safety

- a) **Hold power tool by insulated gripping surfaces, when performing an operation where the fastener may contact hidden wiring.** Fasteners contacting a "live" wire may make exposed metal parts of the power tool "live" and could give the operator an electric shock.

- b) **Wear ear protectors.** Exposure to noise can cause hearing loss.
- c) **Use auxiliary handles, if supplied with the tool.** Loss of control can cause personal injury.
- d) **Breathing protection must be worn if the power tool is used without a dust removal system for work that creates dust.**
- e) **Improve the blood circulation in your fingers by relaxing your hands and exercising your fingers during breaks between working.**
- f) **Avoid touching rotating parts. Switch the power tool on only after bringing it into position at the workpiece.** Touching rotating parts, especially rotating insert tools, may lead to injury.
- g) **Activate the safety lock (forward / reverse switch in the middle position) before storing or transporting the power tool.**
- h) **Children must be instructed not to play with the power tool.**
- i) **The power tool is not intended for use by children, by debilitated persons or those who have received no instruction or training.**
- j) Dust from material such as paint containing lead, some wood species, minerals and metal may be harmful. Contact with or inhalation of the dust may cause allergic reactions and/or respiratory diseases to the operator or bystanders. Certain kinds of dust are classified as carcinogenic such as oak and beech dust especially in conjunction with additives for wood conditioning (chromate, wood preservative). Material containing asbestos must only be treated by specialists. **Where the use of a dust extraction device is possible it shall be used. To achieve a high level of dust collection, use a suitable vacuum cleaner of the type recommended by Hilti for wood dust and/or mineral dust together with this tool. Ensure that the workplace is well ventilated. The use of a dust mask of filter class P2 is recommended. Follow national requirements for the materials you want to work with.**

5.2.2 Power tool use and care

- a) **Secure the workpiece. Use clamps or a vice to secure the workpiece.** The workpiece is thus held more securely than by hand and both hands remain free to operate the power tool.
- b) **Check that the insert tools used are compatible with the chuck system and that they are secured in the chuck correctly.**
- c) **Ensure fastener and attachment will withstand the level of torque generated by the tool.** Excessive torque may overstress, strip or damage the fastener/attachment and possibly lead to personal injury.

5.2.3 Cordless tool use and care

- a) **Ensure the switch is in the off position before inserting battery pack.** Inserting the battery pack into power tools that have the switch on invites accidents.
- b) **Do not expose batteries to high temperatures or fire.** This presents a risk of explosion.
- c) **Do not disassemble, squash or incinerate batteries and do not subject them to temperatures over 80°C.** A risk of fire, explosion or injury through contact with caustic substances may otherwise result.
- d) **Avoid ingress of dampness.** Dampness may cause a short circuit resulting in a risk of burning injury or fire.
- e) **Do not use batteries other than those approved for use with the applicable power tool or appliance.** Use of other batteries or use of the battery for purposes for which it is not intended presents a risk of fire and explosion.
- f) **Observe the special instructions applicable to the transport, storage and use of Li-ion batteries.**
- g) **Remove the battery before storing or transporting the power tool.**
- h) **Avoid short-circuiting the battery. Check that the terminals on the battery and in the power tool are free from foreign objects before inserting the battery in the power tool.** Short circuiting the battery terminals presents a risk of fire, explosion and chemical burns.
- i) **Do not charge or continue to use damaged batteries (e.g. batteries with cracks, broken parts, bent or pushed-in and/or pulled-out contacts).**

- j) If the battery gets too hot to touch, this may indicate that it is faulty. **Place the tool in a location where it can be kept under observation, well away from flammable materials, and allow it to cool down. Contact Hilti Service after the battery has been allowed to cool.**

5.2.4 Electrical safety



Before beginning work, check the working area (e.g. using a metal detector) to ensure that no concealed electric cables or gas and water pipes are present. External metal parts of the power tool may become live, for example, when an electric cable is damaged accidentally. This presents a serious risk of electric shock.

5.2.5 Work area

- a) **Ensure that the workplace is well lit.**
 b) **Ensure that the workplace is well ventilated.** Exposure to dust at a poorly ventilated workplace may result in damage to the health.

5.2.6 Personal protective equipment



The user and any other persons in the vicinity must wear suitable eye protection, a hard hat, ear protection, protective gloves and breathing protection while the tool is in use.

6 Before use



6.1 Battery use and care

NOTE

Battery performance drops at low temperatures. Use the tool only after fully charging the battery. This ensures that maximum battery capacity is available. Change to a second battery as soon as a drop in performance is noticed. Recharge the battery immediately so that it is ready for reuse.

Store the battery in a cool, dry place. Never store the battery where it is exposed to direct sunlight or sources of heat, e.g. on heaters / radiators or behind a motor vehicle windscreen. Batteries that have reached the end of their life must be disposed of safely and correctly to avoid environmental pollution.

6.2 Charging the battery



DANGER

Only use the specified Hilti battery packs and Hilti battery chargers which are listed under "Accessories".

6.2.1 Charging a new battery for the first time

Charge the battery fully before using it for the first time.

6.2.2 Charging a previously used battery

Ensure that the outer surfaces of the battery are clean and dry before inserting it in the corresponding charger.

Read the operating instructions for the charger for further information about the charging procedure.

Lithium-ion battery packs are ready to use at any time, even when only partially charged. Charging progress is indicated by the LED display (see charger operating instructions).

6.3 Fitting the battery

CAUTION

Before fitting the battery, check that the power tool is switched off and that the safety lock is engaged (forward/reverse switch in the middle position). Use only the Hilti batteries approved for use with this power tool.

CAUTION

Check that the terminals on the battery and in the power tool are free from foreign objects before inserting the battery in the power tool.

1. Push the battery into the power tool from the rear as far as it will go and until it is heard to engage with a double click.
2. **CAUTION If it is not fitted securely, the battery could fall out while you are working with the tool.**

CAUTION A falling battery may present a risk of injury to yourself or others.

Before beginning the work, check that the battery is fitted securely to the tool.

6.4 Removing the battery 2

1. Press one or both release buttons.
2. Pull the battery out of the power tool toward the rear.

6.5 Transport and storage of battery packs

Pull the battery pack out of the locked position (working position) and move it into the first click-stop position (transport position).

If you disconnect a battery pack from the power tool for transport or storage, make sure that the contacts of the battery pack are not short-circuited. Remove loose metal parts such as screws, nails, clamps, loose screw bits, wires or metal swarf from the case, toolbox or transport container, or prevent these parts from coming into contact with the battery packs.

Observe national and international transport regulations when shipping battery packs (transportation by road, rail, sea or air).

7 Operation

7.1 Changing insert tools

CAUTION

Wear protective gloves when changing insert tools as the insert tools get hot during use.

Check that the connection end of the insert tool is clean. Clean the connection end if necessary.

7.1.1 Changing insert tools with the SID 14-A and SID 22-A

NOTE

The power tool is equipped with a 1/4" hex. socket chuck with locking ring.

7.1.1.1 Fitting the screwdriving bit 3

1. Set the forward / reverse switch to the middle position or remove the battery from the power tool.
2. Push the bit into the chuck as far as it will go (until it engages).

7.1.1.2 Removing the screwdriving bit 4

1. Set the forward / reverse switch to the middle position or remove the battery from the power tool.
2. Pull the locking ring on the chuck forward and hold it in this position.
3. Pull the screwdriving bit out of the chuck and then release the locking ring.

7.1.2 Changing insert tools with the SIW 14-A and SIW 22-A

NOTE

The power tool is equipped with two different chucks: 1/2" square drive with ball-notch retention or 3/8" with locking ring

en

7.1.2.1 Fitting the socket

1. Set the forward / reverse switch to the middle position or remove the battery from the power tool.
2. Align the hole in the side of the socket with the retention ball on the square drive.
3. Push the socket onto the square drive until it engages.

7.1.2.2 Removing the socket

1. Set the forward / reverse switch to the middle position or remove the battery from the power tool.
2. Through the round hole in the side of the socket, press the retention ball into the square drive.
3. Pull the socket off the square drive.

7.2 Setting forward or reverse rotation

NOTE

The forward / reverse switch is used to select the direction of rotation of the drive spindle. An interlock prevents switching while the motor is running. The control switch is locked when the forward / reverse switch is in the middle position. Push the forward / reverse switch to the right (as seen in the working direction) for forward rotation. Push the forward / reverse switch to the left (as seen in the working direction) for reverse rotation.

NOTE

The power tool's working light is no substitute for good general illumination of the working area.

7.3 Torque selector switch

The torque selector switch can be used to set the torque to one of three settings (see Technical Data section).

Slide the switch to the desired torque setting.

7.4 Switching on / off

The speed of the power tool can be controlled smoothly (increased from minimum to maximum) by pressing the control switch gradually.

7.5 Driving screws and tightening bolts

7.5.1 Fitting the bit / bit holder

1. Set the forward / reverse switch to the middle position or remove the battery from the power tool.
2. Fit the appropriate insert tool in the chuck.

7.5.2 Screwdriving

WARNING

Ensure fastener and attachment will withstand the level of torque generated by the tool. Excessive torque may overstress, strip or damage the fastener/attachment and possibly lead to personal injury.

1. Set the forward / reverse switch to the desired direction of rotation.
2. Set the torque selector switch to the desired torque.

7.6 Reading the charge status LED display on Li-ion batteries

NOTE

The charge status cannot be indicated while the power tool is in operation. Indication is given (LED 1 blinks) only when the battery is fully discharged or when it is too hot (temperature above 80°C).

The Li-ion battery features a charge status LED display. The charge status is indicated by the LEDs on the battery during charging (please refer to the section "Li-ion battery charge status"). When the battery is at rest (not in use), its charge status is indicated by the four LEDs on the battery for a time of three seconds after pressing one of the battery release buttons.

7.7 Belt hook

CAUTION

Check that the belt hook is fitted securely before beginning work.

en The belt hook allows the power tool to be attached to a belt worn by the operator. The belt hook can also be fitted to the other side of the power tool for use by left-handed persons.

1. Pull the battery out of the tool.
2. Fit the mounting plate into the guides provided.
3. Secure the belt hook with the two screws.

8 Care and maintenance

CAUTION

Before beginning cleaning, remove the battery from the power tool in order to prevent unintentional starting.

8.1 Care of insert tools

Clean off dirt and dust deposits adhering to the insert tools and protect them from corrosion by wiping the insert tools from time to time with an oil-soaked rag.

8.2 Care of the power tool

CAUTION

Keep the power tool, especially its grip surfaces, clean and free from oil and grease. Do not use cleaning agents which contain silicone.

The outer casing of the power tool is made from impact-resistant plastic. Sections of the grip are made from a synthetic rubber material.

Never operate the power tool when the ventilation slots are blocked. Clean the ventilation slots carefully using a dry brush. Do not permit foreign objects to enter the interior of the power tool. Clean the outside of the power tool at regular intervals with a slightly damp cloth. Do not use a spray, steam pressure cleaning equipment or running water for cleaning. This may negatively affect the electrical safety of the power tool.

8.3 Maintenance

WARNING

Repairs to the electrical section of the power tool may be carried out only by trained electrical specialists.

Check all external parts of the power tool for damage at regular intervals and check that all controls operate faultlessly. Do not operate the power tool if parts are damaged or when the controls do not function faultlessly. If necessary, the power tool should be repaired by Hilti Service.

8.4 Care of the Li-ion battery

Avoid entrance of moisture.

Charge the battery fully before using it for the first time.

In order to achieve maximum battery life, stop discharging the battery as soon as a significant drop in performance is noticed.

NOTE

If use of the power tool continues, further battery discharge will be stopped automatically before the battery cells suffer damage.

Charge the battery with the Hilti charger approved for use with Li-ion batteries.

NOTE

- A conditioning charge (as is required with NiCd or NiMH batteries) is not necessary.
- Interruption of the charging procedure has no negative effect on battery life.
- Charging can be started at any time with no negative effect on battery life. There is no memory effect (as with NiCd or NiMH batteries).
- For best results, batteries should be stored fully charged in a cool dry place. Avoid charging the battery in places subject to high ambient temperatures (e.g. at a window) as this has an adverse effect on battery life and increases the rate of self-discharge.
- If the battery no longer reaches full charge, it may have lost capacity due to aging or overstraining. It is possible to

continue working with a battery in this condition but it should be replaced in good time.

8.5 Checking the power tool after care and maintenance

After carrying out care and maintenance work on the power tool, check that all protective and safety devices are fitted and that they function faultlessly.

en

9 Troubleshooting

Fault	Possible cause	Remedy
The power tool doesn't run.	The battery is discharged or fitted incorrectly.	The battery must be heard to engage with a double click or, respectively, needs to be charged.
	Electrical fault.	Remove the battery from the power tool and contact Hilti Service.
The on / off switch can't be pressed, i.e. the switch is locked.	The forward / reverse switch is in the middle position (transport lock engaged).	Push the forward / reverse switch to the left or right.
Running speed suddenly drops considerably.	The battery is discharged.	Change the battery and recharge the discharged battery.
The battery runs down more quickly than usual.	Battery condition is not optimal.	Have battery condition diagnosed by Hilti Service or replace with a new battery.
The battery doesn't engage with an audible click.	The retaining lugs on the battery are dirty.	Clean the retaining lugs and check that the battery engages securely. Contact Hilti Service if the problem persists.
The power tool or the battery become very warm.	Electrical fault.	Switch the power tool off immediately, remove the battery and contact Hilti Service.
	The power tool has been overloaded (application limits exceeded).	Use the right power tool for the job (don't use a low-powered tool for heavy work).

10 Disposal

CAUTION

Improper disposal of the equipment may have serious consequences: the burning of plastic components generates toxic fumes which may present a health hazard. Batteries may explode if damaged or exposed to very high temperatures, causing poisoning, burns, acid burns or environmental pollution. Careless disposal may permit unauthorized and improper use of the equipment. This may result in serious personal injury, injury to third parties and pollution of the environment.

CAUTION

Dispose of defective batteries without delay. Keep them out of reach of children. Do not attempt to open or dismantle batteries and do not dispose of them by incineration.

CAUTION

Dispose of the batteries in accordance with national regulations or return them to Hilti.



Most of the materials from which Hilti power tools or appliances are manufactured can be recycled. The materials must be correctly separated before they can be recycled. In many countries, Hilti

has already made arrangements for taking back your old power tools or appliances for recycling. Please ask your Hilti customer service department or Hilti representative for further information.

en



For EC countries only

Disposal of electric tools together with household waste is not permissible.

In observance of the European Directive on waste electrical and electronic equipment and its implementation in accordance with national law, electrical appliances that have reached the end of their life must be collected separately and returned to an environmentally compatible recycling facility.

11 Manufacturer's warranty - tools

Hilti warrants that the tool supplied is free of defects in material and workmanship. This warranty is valid so long as the tool is operated and handled correctly, cleaned and serviced properly and in accordance with the Hilti Operating Instructions, and the technical system is maintained. This means that only original Hilti consumables, components and spare parts may be used in the tool.

This warranty provides the free-of-charge repair or replacement of defective parts only over the entire lifespan of the tool. Parts requiring repair or replacement as a result of normal wear and tear are not covered by this warranty.

Additional claims are excluded, unless stringent national rules prohibit such exclusion. In particular, Hilti is not obligated for direct, indirect, incidental or consequential damages, losses or expenses in connection with, or by reason of, the use of, or inability to use the tool for any purpose. Implied warranties of merchantability or fitness for a particular purpose are specifically excluded.

For repair or replacement, send the tool or related parts immediately upon discovery of the defect to the address of the local Hilti marketing organization provided.

This constitutes Hilti's entire obligation with regard to warranty and supersedes all prior or contemporaneous comments and oral or written agreements concerning warranties.

12 EC declaration of conformity (original)

Designation:	Cordless impact screwdriver / wrench
Type:	SID 14-A / SID 22-A / SIW 14-A / SIW 22-A
Generation:	01
Year of design:	2010

We declare, on our sole responsibility, that this product complies with the following directives and standards: 2006/42/EC, 2004/108/EC, 2006/66/EC, 2011/65/EU, EN 60745-1, EN 60745-2-2, EN ISO 12100.

Hilti Corporation, Feldkircherstrasse 100, FL-9494 Schaan

Paolo Luccini
Head of BA Quality and Process Management

Business Area Electric Tools & Accessories
08/2011

Jan Doongaji
Executive Vice President

Business Unit Power Tools & Accessories
08/2011

Technical documentation filed at:

Hilti Entwicklungsgesellschaft mbH
Zulassung Elektrowerkzeuge
Hiltistrasse 6
86916 Kaufering
Deutschland

2.3 供货提供的部件包括 (纸板盒版本) :

- 1 电动工具
- 1 操作说明

2.4 操作电动工具所需的其它部件 :

B 22/1.6 Li-Ion、B 22/2.6 Li-Ion、B 22/3.3 Li-Ion、B 14/1.6 Li-Ion 或 B 14/3.3 Li-Ion 电池, 搭配 C4/36-90、C4/36-350、C 4/36、C 4/36-ACS 或 C 4/36-ACS TPS 充电器。

2.5 锂离子电池充电状态

LED 持续亮起	LED 闪烁	充电状态 C
LED 1、2、3、4	-	$C \geq 75\%$
LED 1、2、3	-	$50\% \leq C < 75\%$
LED 1、2	-	$25\% \leq C < 50\%$
LED 1	-	$10\% \leq C < 25\%$
-	LED 1	$C < 10\%$

3 插入工具、配件

名称	缩写	说明
套头夹		S-BH 50
用于锂离子电池的充电器	C 4/36-ACS	
用于锂离子电池的充电器	C 4/36	
用于锂离子电池的充电器	C 4/36-90	
用于锂离子电池的充电器	C 4/36-350	
电池	B 14/3.3、B 14/1.6 Li-Ion	
电池	B 22/2.6、B 22/1.6 Li-Ion	
电池	B 22/3.3 Li-Ion	
带钩		

名称	说明
套头	六角套头、套头夹、带六角形刀柄的钻头
套筒	冲击扳手机套筒

4 技术数据

保留作出技术更改的权利！

电动工具	SID 14-A	SIW 14-A
额定电压	14.4 V	14.4 V
重量 (包括电池和夹头), 按照 EPTA 标准 01/2003	1.3 kg	1.3 kg
尺寸 (L x W x H)	151 mm x 81 mm x 228 mm	154 mm x 81 mm x 228 mm
额定空载运行转速, 位置 I	0...1,000/min	0...1,000/min
额定空载运行转速, 位置 II	0...1,500/min	0...1,500/min
额定空载运行转速, 位置 III	0...2,500/min	0...2,300/min
冲击速度	最大 3,100 bpm	最大 3,400 bpm
速度调节	三个设置	三个设置
标准螺钉	M8 - M16	M8 - M16
高强度螺钉	M6 - M12	M6 - M12
夹头	1/4" 带锁止衬套的六角套筒	带固定球耳的 1/2" 方榫和带锁止环的 3/8" 方榫

电动工具	SID 14-A	SIW 14-A
速度控制	电子控制, 通过控制开关	电子控制, 通过控制开关
前进/后退	带联锁装置的电子开关, 防止在运行时发生切换	带联锁装置的电子开关, 防止在运行时发生切换
深度放电保护	是	

电动工具	SID 22-A	SIW 22-A
额定电压	21.6 V	21.6 V
重量 (包括电池和夹头), 按照 EPTA 标准 01/2003	1.5 kg	1.5 kg
尺寸 (L x W x H)	151 mm x 94 mm x 228 mm	154 mm x 94 mm x 228 mm
额定空载运行转速, 位置 I	0...1,000/min	0...1,000/min
额定空载运行转速, 位置 II	0...1,500/min	0...1,500/min
额定空载运行转速, 位置 III	0...2,500/min	0...2,300/min
冲击速度	最大 3,450 bpm	最大 3,500 bpm
速度调节	三个设置	三个设置
标准螺钉	M8 - M16	M8 - M16
高强度螺钉	M6 - M12	M6 - M12
夹头	1/4" 带锁止衬套的六角套筒	带固定球耳的 1/2" 方榫和带锁止环的 3/8" 方榫
速度控制	电子控制, 通过控制开关	电子控制, 通过控制开关
前进/后退	带联锁装置的电子开关, 防止在运行时发生切换	带联锁装置的电子开关, 防止在运行时发生切换
深度放电保护	是	是

-注意-

扭矩选择开关可用来选择三个扭矩设置。

电动工具	位置 I	位置 II	位置 III
SID 14-A	50 Nm	100 Nm	150 Nm
SIW 14-A (3/8" 方榫)	65 Nm	115 Nm	160 Nm
SIW 14-A (1/2" 方榫)	80 Nm	120 Nm	185 Nm
SID 22-A	60 Nm	110 Nm	165 Nm
SIW 22-A (3/8" 方榫)	75 Nm	120 Nm	175 Nm
SIW 22-A (1/2" 方榫)	90 Nm	135 Nm	200 Nm

-注意-

本信息表中给出的振动传导水平是按照 EN 60745 中给定的标准化测试进行测量的, 可用于比较一个工具与另一个工具。它还可用于初步评价受振动影响的程度。表中发布的振动传导水平只适用于本电动工具的主要应用场合。如果将电动工具用于不同的应用场合、使用不同的配件或维护不良, 则振动传导水平可能不同, 而且这可能会显著增加操作者在整个工作期间受振动影响的程度。对受振动影响程度的估计还应考虑当关闭电动工具或当它运行但实际未进行工作时情况, 这样可以显著减少操作者在整个工作期间受振动影响的程度。此外, 应确定附加安全措施, 以保护操作者免受振动影响, 例如: 正确维护电动工具和配件、保持双手温暖、制订合理的工作计划等。

噪音信息 (按照 EN 60745-1 测量):

SID 14-A 和 SIW 14-A 典型的 A 94 dB (A) 加权声功率级
SID 22-A 和 SIW 22-A 典型的 A 97 dB (A) 加权声功率级
SID 14-A 和 SIW 14-A 典型的 A 83 dB (A) 加权声压级

SID 22-A 和 SIW 22-A 典型的 A 86 dB (A)
加权声压级

给定声级的不确定性 3 dB (A)

遵照 EN 60745 的附加信息

三维振动值 (振动向量和) 按照 EN 60745-2-2 测量

SID 22-A 和 SIW 22-A 冲击驱动 11 m/s²
最大尺寸紧固件时, a_h

SID 14-A 和 SIW 14-A 冲击驱动 7.5 m/s²
最大尺寸紧固件时, a_h

不确定性 (K) 1.5 m/s²

电池	B 22/1.6 Li-Ion	B 22/2.6 Li-Ion	B 22/3.3 Li-Ion
额定电压	21.6 V	21.6 V	21.6 V
电池容量	1.6 Ah	2.6 Ah	3.3 Ah
能含量	34.56 Wh	56.16 Wh	71.28 Wh
重量	0.48 kg	0.78 kg	0.78 kg
温度监控	是	是	是
单元格类型	锂离子	锂离子	锂离子
单元格数量	6	12	12

电池	B 14/1.6 Li-Ion	B 14/3.3 Li-Ion
额定电压	14.4 V	14.4 V
电池容量	1.6 Ah	3.3 Ah
能含量	23.04 Wh	47.52 Wh
重量	0.36 kg	0.58 kg
温度监控	是	是
单元格类型	锂离子	锂离子
单元格数量	4	8

cn

5 安全说明

-注意-

章节5.1中的安全规定包括电动工具的所有一般性安全规定, 按照适用标准, 需要将这些安全规定列在操作说明中。因此, 所列的某些规定可能与本电动工具无关。

5.1 一般电动工具安全警告

a) -警告-

请阅读所有安全警告和操作说明。不遵守安全警告和操作说明可能会导致电击、火灾和/或严重人身伤害。请保存所有安全警告和操作说明, 以供将来参考。在所有警告中, 词语“电动工具”是指您的通过主电源操作的电动工具 (带电缆) 或通过自身电池操作的电动工具 (不带电缆)。

5.1.1 工作区域安全

- 保持工作区域清洁并具有良好的照明。杂乱或黑暗的区域容易导致事故。
- 不要在爆炸性环境中操作电动工具, 例如有易燃液体、气体或灰尘。电动工具会产生可以点燃这些灰尘或烟雾的火花。
- 在操作电动工具时, 要令儿童和旁观者远离工作现场。万一分心, 可能会使您失去对电动工具的控制。

5.1.2 电气安全

- 电动工具插头必须匹配电源插座。切勿以任何方式改动插头。对于接地的电动工具, 不要使用任何适配器插头。使用未经改动的插头和匹配的电源插座可以大大减少电击危险。
- 避免身体接触到接地的表面, 例如管路、散热器、炉灶和冰箱。如果您的身体接地, 则会增加电击危险。
- 不要将电动工具暴露在雨水或潮湿环境中。电动工具进水将会增加电击危险。
- 不要滥用电缆。切勿使用电缆运送、拉动或拔出电动工具。保持电缆远离高温、油、锋利边缘或运动部件。电缆损坏或缠绕会增加电击危险。
- 当在户外操作电动工具时, 应使用经认可适合户外操作的加长电缆。使用适合户外操作的电缆可减少电击危险。
- 若不可避免要在潮湿位置操作电动工具, 则应使用剩余电流装置 (RCD) 保护电源。使用 RCD 可减小电击危险。

5.1.3 人身安全

- a) 保持警觉，注意您正在进行的工作，并在操作电动工具的过程中，应利用自己的判断能力。当您疲劳或受到药物、酒精或医疗影响时，请不要使用电动工具。当操作电动工具时，瞬间的分心都可能导致严重的人身伤害。
- b) 使用个人防护装备。一定要戴上护目装置。防尘罩、防滑安全鞋、安全帽或用于适当情况下的听觉防护装置等防护装备可减少人身伤害。
- c) 防止电动工具意外启动。在连接至电源和/或电池组、拿起或搬运电动工具之前，应确保开关处于“关闭”位置。将手指放在开关上搬运电动工具或在开关处于“打开”位置时接通电源，都可能会导致事故发生。
- d) 在打开电动工具之前，必须拿掉任何调整键或扳手。让扳手或调整键留在电动工具的旋转部件上可能会导致人身伤害。
- e) 不要操之过急。应时刻保持正确的站姿和平衡。这在意外情况下能够更好地控制电动工具。
- f) 应正确穿着。不要穿着松垮的衣服或佩戴首饰。让头发、衣服和手套远离运动部件。松垮的衣服、首饰或长发会卡在运动部件中。
- g) 如果提供有用于连接除尘和集尘设施的装置，应确保将它们连接好并正确使用。使用除尘装置可以减少与灰尘相关的危险。

5.1.4 电动工具的使用和维护

- a) 不要强制使用电动工具。针对您的应用场合使用正确的电动工具。正确的电动工具在其额定设计值范围内将能够更好和更安全地工作。
- cn b) 如果通过开关不能使其打开和关闭，则请不要使用电动工具。任何不能通过开关进行控制的电动工具都是危险的，必须对其进行修理。
- c) 在进行任何调整、更换配件或存放电动工具之前，应从电源上断开插头和/或从电动工具上断开电池组。此预防性安全措施可减少意外启动电动工具的危险。
- d) 将不用的电动工具存放在儿童够不到的地方，并且不要让不熟悉电动工具或其操作说明的人员操作电动工具。在未经培训的用户手里，电动工具是危险的。
- e) 维护电动工具。检查是否存在运动部件失调或卡滞、部件断裂和任何其它影响电动工具操作的情况。如果存在损坏，则在使用之前应修理电动工具。许多事故都是由于电动工具维护不良造成的。
- f) 保持切削工具锋利和清洁。带锋利切削刃的切削工具如果维护得当，很少会发生卡滞且更容易控制。
- g) 按照操作说明使用电动工具、配件和钻头，并将工作条件和将要执行的工作考虑在内。将电动工具用于指定用途以外的场合会导致危险。

5.1.5 无绳(电池操作)工具的使用和维护

- a) 充电时只能使用制造商指定的充电器。适合某种类型电池组的充电器如果被用于为另一类型电池组充电，则可能会带来火灾危险。
- b) 只能使用专用电池组为电动工具供电。使用任何其它电池组可能会带来人身伤害和火灾。
- c) 当电池组不用时，应使其远离其它金属物体，例如纸夹、硬币、钥匙、钉子、螺钉或其它小的金属物体，以免造成短路。如果电池端子被短路，则会造成人员烧伤或火灾。
- d) 如果持续滥用电池，则可能会造成液体从电池中喷射出来；注意避免接触到液体。如果意外接触到液体，应用水冲洗。如果液体接触眼睛，除了用大量清水冲洗外，还应立即就医。从电池中喷射出来的液体会导致疼痛或灼伤。

5.1.6 维修

- a) 您的电动工具只能由合格的维修人员使用原装备件进行修理。这样才可确保维持电动工具的安全性。

5.2 附加安全预防措施

5.2.1 人身安全

- a) 当执行紧固件可能会接触到隐藏导线的操作时，应确保只能通过绝缘把手表面握住电动工具。如果紧固件接触“带电”导线，则会使电动工具的裸露金属部件“带电”，从而可能会电击到操作者。
- b) 戴上护耳装置。如果直接暴露在噪音中，则可能会导致听力受损。
- c) 使用随工具一起提供的辅助手柄(若有)。对工具失去控制可能会导致人身伤害。

- d) 当所进行的工作会产生灰尘时，如果在没有除尘系统的情况下使用电动工具，则必须戴上呼吸防护装置。
- e) 在工作期间休息时，可活动一下您的手指，以改善手指的血液循环。
- f) 避免接触旋转部件。仅在将电动工具带到工作位置时才可打开电动工具。接触旋转部件，特别是旋转起来的插入工具，会导致伤害。
- g) 在存放或运输电动工具之前，应启动安全锁（前进/后退开关处于中间位置）。
- h) 必须告知儿童不要玩耍本电动工具。
- i) 儿童、没有经过培训或没有接受过指导的人以及劳累过度的人不适合使用本电动工具。
- j) 一些材料产生的灰尘，例如含铅油漆、某些木屑、矿物和金属，可能对人体有害。接触或吸入这些灰尘可能会导致操作者或旁观者出现过敏反应和/或呼吸疾病。某些种类的灰尘还属于致癌物质，例如橡木和山毛榉木灰尘，特别是在带木材调节添加剂（铬酸盐、木材防腐剂）时。含石棉的材料只能由专业人员进行处理。在能使用除尘装置时应尽可能使用。为达到高水平的除尘效果，在使用本电动工具时，应使用 Hilti 公司推荐的适合于木材灰尘和/或矿物灰尘的真空吸尘器类型。确保工作场所良好通风。建议使用过滤等级为 P2 的防尘面罩。遵守有关工作材料的国家要求。

5.2.2 电动工具的使用和维护

- a) 固定工件。必要时可使用夹子或台钳固定工件。这样，工件可比用手固定更稳固，而且可以腾出双手来操作电动工具。
- b) 检查并确认所用的插入工具兼容夹头系统并且它们正确固定在夹头中。
- c) 确保紧固件和附件能够承受电动工具产生的扭矩等级。过大的扭矩可能会使紧固件/附件承受过应力，或折断/损坏紧固件/附件，也可能造成人身伤害。

cn

5.2.3 无绳电动工具的使用和维护

- a) 在插入电池组之前，应确保开关处于“关闭”位置。如果在开关处于“打开”位置的情况下将电池组插入电动工具，则会很容易导致事故。
- b) 不得将电池暴露在高温或明火环境下。否则会有爆炸危险。
- c) 请勿拆开、挤压或烧毁电池，不要让它们暴露在高于 80 °C 的高温下。与腐蚀性物质接触可能会导致火灾、爆炸或人身伤害危险。
- d) 避免湿气侵入。湿气可能会导致短路，从而引起烧伤或火灾。
- e) 不得将未经许可的电池用于为电动工具或设备供电。如果使用其它电池或将电池用于非指定用途，则会有火灾和爆炸危险。
- f) 遵守有关锂离子电池运输、存放和使用的特殊说明。
- g) 在存储或运输电动工具之前，必须拆下电池。
- h) 避免令电池短路。在将电池插入电动工具前，检查并确保电池和电动工具的端子无异物。如果电池端子短路，则存在火灾、爆炸和化学烧伤的危险。
- i) 对于已损坏的电池（例如出现裂纹、部件断裂、触点弯曲或压入和/或拉出的电池），请不要充电或继续使用。
- j) 若电池变得过热而不能触摸，则表明有故障。将本工具置于可观察到的位置，使其远离易燃材料，并让其冷却下来。在电池已冷却后，即联系喜利得维修部门。

5.2.4 电气安全



在开始工作之前，应检查工作区域（例如使用金属探测器）以确保没有隐藏的电缆或煤气管和水管。如果有电缆意外受损，则电动工具的外部金属部件可能会因接触而带电。这会导致严重的电击危险。

5.2.5 工作区域

- a) 确保工作场所保持良好照明。
- b) 确保工作场所良好通风。在通风不良的工作场所下灰尘极易损害人体健康。

5.2.6 个人防护装备



当使用电动工具时，用户和附近的任何其他人员都必须戴上适当的护目装置、安全帽、护耳装置、防护手套和呼吸防护装置。

6 在使用之前



6.1 电池的使用和维护

-注意-

电池性能在低温时会下降。仅在对电池完全充电后才可使用本工具。这可确保获得最大的电池容量。一旦注意到电池性能下降，应立即换用另一电池组。立即为电池再充电，以便为再次使用做好准备。

将电池存放在凉爽、干燥的地方。切勿将电池存放在阳光直射或热源处，例如在加热器/散热器上或汽车挡风玻璃的后面。已经达到使用寿命极限的电池必须进行安全和正确的废弃处理，并避免环境污染。

6.2 为电池充电



-危险-

只能使用规定的喜利得电池组和喜利得电池充电器（已在“配件”中列明）。

6.2.1 首次为新电池充电

在首次使用电池之前，要给电池完全充电。

6.2.2 为先前使用过的电池充电

在将电池插入相应的充电器之前，应确保电池外表面清洁和干燥。有关充电步骤的更多详细信息，请参考充电器的操作说明。

锂离子电池组可随时投入使用，即使当仅充部分电量时。通过 LED 显示指示充电进度（参见充电器操作说明）。

6.3 安装电池

-小心-

在安装电池之前，检查并确认电动工具是关闭的，且安全锁已接合（前进/后退开关处于中间位置）。仅可使用适用于本电动工具的喜利得电池。

-小心-

在将电池插入电动工具前，检查并确保电池和电动工具的端子无异物。

1. 将电池从后部推入电动工具中，推到底，直至听到接合的“双咔哒”声。
2. -小心- 如果未牢固安装，则在使用电动工具期间电池可能会掉出来。
-小心- 如果电池掉落，则可能会对自己或他人造成人身伤害。
在开始工作之前，检查并确保电池已牢固安装在工具中。

6.4 拆下电池 2

1. 按下一个或两个释放按钮。
2. 将电池朝后拉出电动工具。

6.5 电池组的运输和存储

将电池组拉出锁止位置 (工作位置) 并移至第一个咔哒止动位 (运输位置)。

如为了运输或存储而从电动工具上拆下电池组, 则应确保电池组的触点不会被短路。将松散的金属部件如螺钉、钉子、夹子、螺钉套头、电线或金属屑等从盒子、工具箱或运输容器中清除出去, 以防止这些部件接触到电池组触点。

当运输电池组时, 请遵守国内和国际的运输规定 (公路、铁路、海上或空中运输)。

7 操作

7.1 更换插入工具

-小心-

当更换插入工具时应戴上防护手套, 因为插入工具在使用过程中会变得很热。

检查并确认插入工具的连接端清洁。必要时清洁连接端。

7.1.1 更换 SID 14-A 和 SID 22-A 的插入工具

-注意-

电动工具配有一个 1/4" 带锁止环的六角套筒夹头。

7.1.1.1 安装螺丝驱动套头 3

1. 将前进/后退开关设置在中间位置或从电动工具上拆下电池。
2. 将套头推入夹头中并推到底 (直至它接合)。

7.1.1.2 拆下螺丝驱动套头 4

1. 将前进/后退开关设置在中间位置或从电动工具上拆下电池。
2. 向前拉动夹头上的锁止环并保持住。
3. 将螺丝驱动套头拉出夹头, 然后释放锁止环。

7.1.2 更换 SIW 14-A 和 SIW 22-A 的插入工具 5

-注意-

电动工具可配备两种不同的夹头: 带固定球耳的 1/2" 方榫或带锁止环的 3/8" 方榫

7.1.2.1 安装套筒

1. 将前进/后退开关设置在中间位置或从电动工具上拆下电池。
2. 将套筒侧面的孔对准方榫上的固定球耳。
3. 将套筒推到方榫上, 直至它接合。

7.1.2.2 拆下套筒

1. 将前进/后退开关设置在中间位置或从电动工具上拆下电池。
2. 通过套筒侧面的圆孔将固定球耳按入方榫。
3. 将套筒从方榫中拉出。

7.2 设置前进或后退旋转 6

-注意-

使用前进/后退开关选择驱动主轴的旋转方向。但在电动机运行时, 联锁装置将会阻止此切换。当前进/后退开关位于中间位置时, 控制开关被锁止。将前进/后退开关推向右侧 (从工作方向上看) 可选择前进旋转。将前进/后退开关推向左侧 (从工作方向上看) 可选择后退旋转。

-注意-

电动工具的工作灯不能替代工作区域的良好照明。

7.3 扭矩选择开关 7

扭矩选择开关可用来选择三个设置中的其中一个 (参见“技术数据”章节)。

将开关滑动至期望的扭矩设置。

7.4 打开/关闭

通过逐渐按下控制开关可平稳控制电动工具的速度 (从最小增加至最大)。

7.5 驱动螺钉和紧固螺栓

7.5.1 安装套头/套头夹

1. 将前进/后退开关设置在中间位置或从电动工具上拆下电池。
2. 将合适的插入工具 (套头/套头夹) 装入夹头中。

7.5.2 螺丝驱动

-警告-

确保紧固件和附件能够承受电动工具产生的扭矩等级。过大的扭矩可能会使紧固件/附件承受过应力，或折断/损坏紧固件/附件，也可能造成人身伤害。

1. 将前进/后退开关设置到期望的旋转方向。
2. 将扭矩选择开关设置至期望的扭矩。

7.6 查看锂离子电池上的充电状态 LED 显示 8

-注意-

当电动工具处于操作状态时，不能指示充电状态。仅当电池已完全放电或当电池过热（温度大于 80 °C）时才会给出指示（LED 1 闪烁）。

锂离子电池具有充电状态 LED 显示功能。充电期间电池上的 LED 显示指示充电状态（请参见章节“锂离子电池充电状态”）。当电池停止工作（未使用）时，在按下其中一个电池释放按钮后，电池上的四个 LED 会指示其充电状态，指示时间为 3 秒钟。

7.7 带钩 9

-小心-

在开始工作之前，检查并确保带钩已可靠安装。

通过带钩可将电动工具连接在操作者佩戴的背带上。带钩也可安装至电动工具的另一侧，以供惯用左手的人使用。

1. 从电动工具上拉出电池。
2. 将安装板安装至提供的导向装置上。
3. 用两个螺钉固定带钩。

cn

8 维护和保养

-小心-

在开始清洁之前，为了防止意外启动，应从电动工具上拆下电池。

8.1 维护插入工具

清除插入工具上的污物和灰尘，并通过使用浸油抹布不时擦拭来防止插入工具出现腐蚀。

8.2 维护电动工具

-小心-

保持电动工具清洁和没有油脂，特别是其把手表面。不要使用含硅的清洁剂。

电动工具的外壳由耐冲击塑料制成。把手部分由合成橡胶材料制成。

当通风槽堵塞时切勿操作电动工具。使用干燥的刷子小心清洁通风槽。不要让异物进入电动工具内部。使用干净微湿抹布定期清洁电动工具外部。不要使用喷雾器、蒸气压力清洁设备或流水进行清洁，否则会给电动工具的电气安全带来不利影响。

8.3 维护

-警告-

只能由经过培训的电气专业人员修理电动工具的电气系统。

定期检查电动工具的所有外部部件是否损坏并检查确认所有控制器都可无故障工作。如果部件损坏或当控制器不能无故障工作时，请不要操作电动工具。必要时，应将电动工具送至 Hilti 公司维修中心进行维修。

8.4 锂离子电池的维护

避免湿气进入。

在首次使用电池之前，要给电池完全充电。

为了获得最长的电池使用寿命，一旦注意到电池性能有明显的下降，应立即停止对电池放电。

-注意-

如果继续使用电动工具，则在电池单元格遭受损坏之前，将会自动停止电池进一步放电。

用经过批准适用于锂离子电池的 Hilti 充电器给电池充电。

-注意-

- 不需要进行调节性充电（这对镍镉或镍氢电池需要）。
- 充电过程中断对电池寿命没有负面影响。
- 随时都可以开始充电，这对电池寿命没有负面影响，但没有记忆效应（镍镉或镍氢电池有）。
- 为了获得最好的结果，电池应在完全充电状态下存放在凉爽、干燥的地方。避免在高温下（如阳光照射的窗户处）给电池充电，因为这对电池寿命有负面影响，并加快其自放电速度。

- 如果电池无法继续达到完全充电状态，则可能是电池因老化或超负载而失去了容量。在这种情况下，可以继续使用电池，但应及时更换。

8.5 在维护和保养之后检查电动工具

在对电动工具进行维护和保养之后，检查并确认所有保护和安全装置都已安装且它们都可无故障地工作。

9 故障排除

故障	可能原因	措施
电动工具不运行。	电池放电或安装不正确。	必须听见电池接合的“双咔哒”声或电池需要相应充电。
	电气故障。	将电池从电动工具上拆下，并联系 Hilti 公司维修中心。
不能按下“打开/关闭”开关，即开关被锁止。	前进/后退开关位于中间位置 (安全锁已接合)。	将前进/后退开关推向左侧或右侧。
运行速度突然明显下降。	电池放电。	更换电池，并对已放电电池充电。
电池比平常更快耗尽。	电池状况不是最佳。	请让 Hilti 公司维修中心诊断电池状况或更换新电池。
电池未接合 (没有发出咔哒声)。	电池上的固定凸耳脏污。	清洁固定凸耳，并检查确认电池已牢固接合。如果问题持续出现，则请联系 Hilti 公司维修中心。
电动工具或电池变得非常热。	电气故障。	立即关闭电动工具，拆下电池并联系喜利得公司维修中心。
	电动工具已过载 (超过应用极限)。	针对工作情况使用正确的电动工具 (不要将低功率工具用于重负荷作业)。

cn

10 废弃处置

-小心-

不正确地废弃处置设备可能会产生严重后果：塑料部件燃烧会产生危害健康的有毒烟雾。电池如果损坏或暴露在极高的温度下，可能会发生爆炸，从而导致中毒、烧伤、酸蚀或环境污染。如果废弃处置疏忽，则可能会造成设备的未授权或不正确的继续使用，从而导致严重的人身伤害、第三方伤害和环境污染。

-小心-

有故障的电池应立即废弃处置。不要让儿童接触到它们。不要试图打开或解体电池，也不要使用焚化方法进行废弃处置。

-小心-

按照国家法规废弃处理电池或将其交回喜利得公司。



Hilti 电动工具或设备的大多数制作材料都可以回收利用。在可以回收之前，必须正确分离材料。在许多国家中，Hilti 公司已经对旧电动工具或设备的回收利用作了安排。有关进一步的信息，请咨询您的 Hilti 公司客户服务部门或 Hilti 公司代表。



仅限于欧洲国家

不允许将电动工具与家用垃圾一起处理！

遵守欧洲指令和地区法律有关废弃电气和电子设备的规定，并且废弃处置的实施应该符合国家法律。必须单独收集已达到使用寿命期限的电气设备，并以环保的方式进行回收。

11 制造商保修 - 工具

Hilti 公司保证工具在出厂时不存在材料和制造工艺方面的缺陷。本保修有效的前提条件是：按照 Hilti 公司操作说明正确操作、处理、清洁和维护工具，并将工具维持在良好的技术状态。这意味着在工具中只能使用 Hilti 公司原装的损耗品、部件和备件。

本保修仅提供在工具整个预期使用寿命期间对有缺陷部件的免费维修或更换。如果部件由于正常磨损而需要进行修理或更换，则不在本保修范围内。

其它的索赔要求均不在本保修范围之内，除非客户所在国家的严格法律存在与此不同的规定。尤其需要强调的是：Hilti 公司在任何情况下均不对因工具使用不当或无法使用而导致的或与之有关的直接性、间接性、偶然性、必然性的物品损坏、财产损失、额外费用负责。本保修范围特别排除商品适销性或特定用途适用性的默示担保。

如需进行修理或更换，在发现故障后应立即将工具或相关部件按照操作说明中提供的地址发送到当地 Hilti 公司营业机构。

以上条款构成了 Hilti 公司在产品保修方面的所有责任，并同时废止此前或同时期涉及到保修的所有口头或书面协议。

cn

12 EC 符合性声明 (原稿)

名称：	充电式冲击电动起子/扳手机
型号：	SID 14-A / SID 22-A / SIW 14-A / SIW 22-A
分代号：	01
设计年份：	2010

按照我们单方面的责任，我们声明本产品符合下列指令和标准：2006/42/EC, 2004/108/EC, 2006/66/EC, 2011/65/EU, EN 60745-1, EN 60745-2-2, EN ISO 12100。

Hilti Corporation, Feldkircherstrasse 100, FL-9494 Schaan

Paolo Luccini
Head of BA Quality and Process
Management
Business Area Electric Tools & Accessories
08/2011

Jan Doongaji
Executive Vice President

Business Unit Power Tools & Accessories
08/2011

技术文档提交于：

Hilti Entwicklungsgesellschaft mbH
Zulassung Elektrowerkzeuge
Hiltistrasse 6
86916 Kaufering
Deutschland



Hilti Corporation

LI-9494 Schaan

Tel.: +423/234 21 11

Fax: +423/234 29 65

www.hilti.com

Hilti = registered trademark of Hilti Corp., Schaan

W 3984 | 0713 | 00-Pos. 8 | 1

Printed in China © 2013

Right of technical and programme changes reserved S. E. & O.

2072653 / A3



2072653