

POWER TOWER

nano

Operating and Maintenance Manual



CONTENTS

Introduction	2
Operating Specifications	3
Working Envelope Diagram	3
Do's and Don'ts	4
Primary Components	5
Operating Procedures (Incl. Emergency Operation)	6-8
Maintenance Procedures (Incl. Castor Safety and Maintenance)	9-13
Storage	14
Key Spare Parts	15-16
Electric Circuit Diagram	17
Hydraulic Circuit Diagram	18
Warranty Terms	19

INTRODUCTION

The Power Tower Nano is designed to be a simple, quick and safe powered alternative to a portable scaffold tower, podium or a step ladder, for construction site and maintenance applications. It can be used in applications where previously portable scaffolding towers are erected on castors, and moved about on hard level surfaces. These types of tower are open to incorrect assembly, and are difficult and time consuming to work from. The Nano eliminates many of the risks associated with portable scaffold towers.

The Nano is suitable for any application provided it is used within its specified operating parameters. If used for applications such as sand blasting, welding, paint spraying or with any other hazardous materials, then measures must be taken to ensure the Nano does not become damaged in any way which may impair safety, or reliability. Additional protection for the operator may be required in some cases, which is the responsibility of the operator and/or the operator's employer.

The purpose of this manual is to provide essential basic information required to operate and maintain the Nano.

Working Dimensions

Maximum working height:	4.50 m
Maximum platform height:	2.50 m
Platform dimensions:	1.00 m x 0.73 m
Working footprint:	1.19 m x 0.75 m
Safe working load:	200 kg (1 person plus tools)
Maximum manual force:	200 N
Max. gradient for operation:	0°
Max. wind force:	Indoor use 0 mph
Manual push force on level ground:	9 kg
Maximum total weight Inc payload:	485 kg
Maximum castor point load:	180 kgs (1.77 kN)
Max. wheel force:	1.75 kN

Closed Dimensions

Length:	1.195 m
Width:	0.750 m
Height:	1.560 m
Weight:	285 kg

Power Source

Standard 12v DC Electric Motor
 Or 240V AC Electric Motor 13A Supply
 Or 110V AC Electric Motor 16A Supply

Battery Charger Specification

Input Voltage:

If single voltage: 90-135V AC (UK)
 180-265V AC (non-UK)

If dual voltage: 90-265V AC

Frequency: 45-65 Hz

Output: 12V DC, 7A

Power sound level: Less than 70dBA

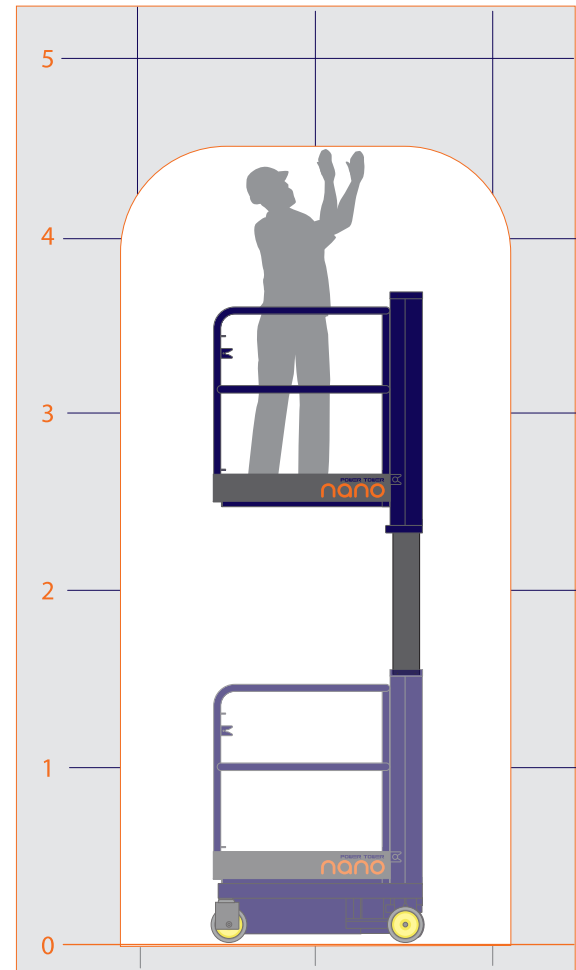
Emission EN 55014N, EN 61000 – 3 – 2

DO'S

1. Read and adhere to the instructions both on the machine and in this manual.
2. Ensure pre-operation checks and operations are carried out in the manner described.
3. Use only on hard, level surfaces able to support the weight of the machine (e.g. concrete floor, tiled floor, hard wood floor).
4. Use the Nano internally only.
5. Ensure operator is fit and does not suffer from a fear of heights.
6. Ensure the Nano is correctly positioned with castor brakes on.
7. Ensure guardrail gate is closed and latched before elevation.
8. Ensure work area around the machine is cordoned off from pedestrians and other traffic.
9. Ensure operator is wearing the correct safety equipment.
10. Ensure the platform is correctly positioned so as not to come into contact with fixed or moving objects.
11. Ensure that the safe working load is evenly distributed on the platform.
12. Never leave the Nano unattended without the castor brakes on.

DON'TS

1. Never exceed the safe working load (1 person, 200kg).
2. Never use the Nano on sloping or uneven ground.
3. Never use the Nano as a goods lift or crane.
4. Never exceed horizontal forces; never use in wind (maximum horizontal force 200N).
5. Never use in the vicinity of live conductors.
6. Never try to move the Nano on its castors when elevated.
7. Never extend the height of the platform by using boxes, steps, ladders etc.
8. Never modify the Nano in any way without the full approval of the manufacturer.
9. Never attempt to enter or exit the platform unless it is fully lowered.
10. Never operate the Nano outside.
11. Never affix the pendant controller to the guardrails or toolbox area of the platform; stow in its holster when not in use.
12. Never use the Nano in an explosive environment.
13. Never use the Nano if fatigued, or under the influence of drugs or alcohol.
14. Never push the Nano on sloping surfaces without the use of a safe method.
15. Never pull or push objects with the platform.

PRIMARY COMPONENT LOCATIONS



OPERATING PROCEDURES

It is essential to be familiar with the correct operating procedures. The operator must have adequate training for this type of platform.

The Nano is fitted with a safety harness point as standard. It is recommended that if the operator chooses to wear a safety harness, an approved 'fall restraint' type harness should be worn.

Operating procedures are divided into three key areas:

1. **Pre-operation checks.**
What to do before operating the Nano.
2. **Normal operation.**
How to use the Nano safely.
3. **Emergency Operation.**
How to lower the Nano without power or in the event of operator incapacity.

There is no specific legal requirement to wear a safety harness. However, there is an employers' requirement to ensure the correct equipment is used for a task and that is used correctly and safely. For this requirement to be met, a risk assessment should be conducted to assess the potential risks and if an increase in operator safety can be achieved with a safety harness, then use a 'fall restraint' type harness only.



PRE-OPERATION CHECKS

1. Ensure there are no obvious signs of mechanical damage to the handrails, platform, lifting structure or chassis.
2. Check castors and wheels rotate freely and are undamaged.
3. Check castor wheel and castor fixings.
4. Check emergency lowering is functioning correctly (refer to procedure on p.8).
5. Ensure the battery (where applicable) is fully charged, referring to the battery condition dial indicator.
6. Ensure the hydraulic oil level is at the correct level. Do not overfill.
7. Check there are no hydraulic oil leaks and that all hydraulic connections are tight.
8. Cordon off area around machine in accordance with guidelines.

NORMAL OPERATION

Only use the Nano internally, on hard level surfaces. Ensure a person is available at ground level to assist in case of emergency.

Position machine under application. Refer to working envelope diagram if necessary.

1. Apply both castor brakes.
2. Check spirit level to ensure machine is level.
3. Ensure the emergency lowering valve is closed (push and twist 90°, release - do not force).
4. Turn key switch in emergency stop button (located at the base of the machine), then pull to release.
5. Battery condition dial indicator on pendant controller will indicate battery charge.
6. Check there are no overhead obstructions.
7. Enter platform via step and gate and ensure the gate is closed and latched correctly when in platform.
8. If using the pendant controller in hand while in the platform do not position the controller (or your hand holding it!) on the guardrails or on top of toolbox. Stow the pendant controller back in its holster after use. Press arrowed button to elevate. ⬆️ Press arrowed button to descend. ⬆️
9. In case of uncontrolled platform elevation or descent, depress red emergency stop button (on pendant controller or at base of machine - refer to pics 4 & 5).



Never affix the pendant controller to the guardrails or toolbox area of the platform.

The user shall obtain the guidance and approval of the manufacturer in the event of any special working methods or conditions which are outside those specified by the manufacturer.

EMERGENCY LOWERING OPERATION

In case of platform control failure or operator incapacity:

To lower the platform:

1. Locate emergency lowering valve at base of machine (see, pic right). Push, twist 90 degrees anti-clockwise and release the knob. The platform will lower. Pushing and twisting the knob clockwise will stop the descent at anytime.
2. Check the area below the platform is free from obstructions when lowering.
3. **Keep clear of descending structure.**

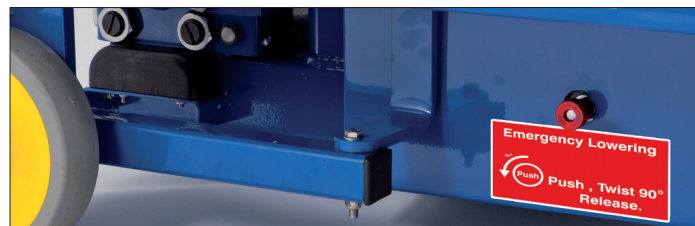

BATTERY CHARGING

The battery charger is located under the checkerplate cover **A**.

The charging lead (usually fitted with a yellow 110V plug) is on the exterior of the machine base (this lead can be fitted with 230V plug if required) **B**. Dual voltage chargers are fully voltage sensitive, so there is no voltage selection to do when connecting to different voltages. If fitted with a single voltage charger, the input voltages are 90-135V AC for UK and 180-265V AC for non-UK.

Ensure the battery isolator is switched on when charging. Plug into an available power supply and ensure the green LED (top of charger) illuminates. The adjacent amber LED has three modes **C**. 1. Rapid flash, indicates maximum charge rate. (Note, when switching charger on, the amber light must rapid flash. If not, there is a fault, check fuse* and connections). 2. Slow pulse, indicates slower charging. 3. Continuous illumination indicates float charge. Both lights go "off" when fully charged. Additionally the battery charge indicator dial on the pendant controller will indicate charge level **D**.

The battery charger can be connected to the mains supply at any time or left for extended periods.

The machine can be operated when the charger is connected, although this is not recommended.

**All mains supply should be protected with a suitable RCD.
Only charge in a well-ventilated area.**

***Note: The charger is fitted with a 15A automotive spade fuse (blue). If the fuse has failed, the indicator lights will still operate. The fuse may have failed if the battery is heavily discharged and the motor is run when the charger is switched on. In such an event, the fuse is simple to replace; ensure battery isolator is switched off and that the mains supply is disconnected before attempting to check or change fuse.**



Please note that whilst the Nano is extremely simple to maintain, all work must be carried out by a competent person.

When removing checkerplate cover for maintenance purposes, first switch off by depressing the emergency stop/battery isolator button located at the base of the machine. Use appropriate safety/personal protective equipment where necessary.

DAILY MAINTENANCE

Tilt cage by releasing gate latch on cage mount (see pic). Pull cage frame from gate end and cage will lift and tilt assisted by gas strut. Ensure gas strut is fully extended and that the safety chock is in place. You can now access the powerpack housing. Unscrew the black retaining knobs and lift out the checkerplate cover.

1. **Check Battery Electrolyte Level:**
Remove battery cover and battery caps. Ensure the electrolyte covers the plates by no more than 1mm – 2mm. Replenish with distilled water to this level, only if the electrolyte level is below the top of the plates.
2. **Check Hydraulic Oil Level:**
Ensure the tank is not overfilled. The level must only be checked when the machine is in the transport position. The correct level in this condition is approximately 3/4 from the base of the tank, as indicated by the line.
3. **Ensure there is no obvious mechanical damage** to the handrails, entrance gate, post or structure of chassis. Also check the castors and wheels are undamaged, rotate freely and are secured to machine.
4. **Check hydraulic connections** around the pump and base of cylinder are tight and undamaged.
5. **Check the spirit level** to ensure it is clearly legible and undamaged.

6. Check all functions operate correctly including movement alarm and emergency stops.
7. Ensure mast surfaces are clean and not greased.



WEEKLY MAINTENANCE

Check battery terminal connections are tight.

MONTHLY MAINTENANCE

Check Battery Specific Gravity:

On a monthly basis check the specific gravity in each of the battery cells. When a battery is correctly fully charged the specific gravity should be 1.27 - 1.3. The specific gravity reading should be equal across the cells, if not repeat the full charge cycle.

Check rollers and mast surfaces for damage. Ensure brushes are fitted correctly and brush against mast surface.

HYDRAULIC OIL

The hydraulic oil must be replaced on an annual basis. If the oil is not replaced, then premature wear and failure of components will occur. To drain the hydraulic tank, the mast must be in the transport position, and the platform tilted to allow access to the motor/pump unit. The only practical method to remove the oil from the tank is to use a syringe suitable for hydraulic oil, which are easily obtainable, or a vacuum system for hydraulic oil. The hydraulic steel pipe connection to the cylinder must not be disconnected, unless by a competent person. If the connection has been disconnected, then a full pressure test of the system must be conducted prior to placing the machine back into service. No leaks must be evident when the pressure test is conducted.

Refill with grade 32 mineral oil.

WHEELS AND CASTORS

It is absolutely essential that the wheels and castors are maintained in good condition at all times, for two reasons:

The first is that they act as the stabilisers, and whilst their load capacity is over rated for the application, any failure could result in a serious accident. Secondly, if the bearings become tight, then it will make the machine difficult to manoeuvre.

A measure of horizontal push force can simply be made to determine the condition of the wheel bearings. On a flat smooth surface the machine should move with a force of 9 – 10 kg at the mid guard rail height. The maximum allowance is 20 kg.

Obviously this force is dependant upon the surface and gradient, but the above is the recognised method of measurement, in accordance with HSE guidelines.

Swivel castor fixing torque: **M12 (NYLOC) 55Nm**

Castor axle torque: **M12 80Nm**

Check rear wheels to ensure retention circlip is securely fitted to end of stub axle and plastic cap is fitted over it.

MOTOR CONTACTOR SOLENOIDS

When conducting the six monthly LOLER inspection, check the correct functioning of the two motor contactors.

Fit new contactors after every three years.

When replacing components for any reason, only use OEM specification parts, either supplied from the manufacturer or authorised in writing by the manufacturer. Warranties and design approvals will be void if alternative components are fitted. It is essential to obtain manufacturer's approval of any alteration which might affect stability, strength or performance in writing before proceeding.

CASTOR SAFETY & MAINTENANCE

In order to ensure the Nano castors are maintained in serviceable and safe condition, regular inspection is required, especially where arduous conditions are known to be involved or there is a suspicion of misuse or abuse. The other key element to ensure is in safe serviceable condition, is the castor fixing bolt, the condition of which can usually be determined from the condition of the castor bracket.

The castor is highly rated for the application so if visible distortion is evident a significant impact will have occurred and under these conditions the castor and fixing must be replaced.

Below are some examples of typical signs of impact which would require castor and fixing replacement.



Side impact and foot pedal distortion as a result of a significant side impact.



Foot pedal distortion as a result of a significant frontal impact; it is likely the top plate and bearing will be distorted as well.



Top mounting plate distortion as a result of a single significant impact or multiple lower level impacts. **Even if the rest of the castor is in good condition, it must be replaced.**

It may be thought feasible to repair the castor in a number of these instances, but serious structural damage will have occurred to the head bearing and castor assembly as well as possibly damage to the main mounting bolt.

Power Towers Limited strongly recommends replacing any castor assembly that is over 3 years old with a new one.

When inspecting a castor in order to determine its serviceability, pay particular attention to the head swivel bearing (compare to a new one if possible) and the boss/rivet which goes through the centre of the swivel bearing and which clamps the assembly together.

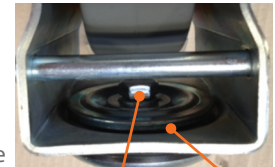

Castor mounting bolt
Swivel bearing head should feel free to rotate and not loose

If the castor is in sound condition, free from distortion then it may be adequate to only replace the main fixing bolt with one of a higher tensile strength, along with a spacer washer that enables a higher bolting torque to be applied. This will improve the reliability of the fix, but will not increase the strength of the castor assembly. The new fixing nut and bolt are to be re-torqued to 55Nm.

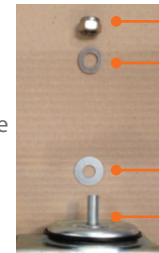

M12 nyloc nut torque to 50Nm.
M12 standard washer.
Special thin spacer washer on top of swivel bearing of castor
M12X16 10.9 bolt

In order to replace the fixing bolt, the wheel axle bolt, half nut and star washer will first need to be removed, along with the central bushing tube and M12 end washers. This enables the wheel to be removed so that the castor fixing bolt can be replaced.

When refitting the wheel, the axle bolt, half nut and star washer, must be replaced with OEM specification new parts and re-torqued to 80Nm. (Pic A) Ensure the axle tube and assembly is lightly greased to ensure a smooth action when operating the foot brake.



Pic A.

MAST MAINTENANCE

Essentially the mast is maintenance free. The mast sections run on maintenance free rollers, and on the outer mast surface where the roller runs, a brush is fitted to keep the mast surface clean, preventing debris picking up in the roller. In addition to these rollers, there are 6 external plastic screws fitted, which act to hold the mast sections together in torsion. These screws are fitted with M24 lock nuts and can easily be identified at the lower end of the mast sections. Inside the mast there are additional wear pads and rollers, which can be accessed from the top of the mast. These items are not adjustable, and it is very unlikely that any wear will occur.

The mast is raised and lowered with a multistage hydraulic piston, which raises the outer mast section first, followed by the middle mast section. When the mast is lowered, the sections close in the reverse sequence i.e. the middle section and outer section close together until the bottom of the middle section contacts the lower rest buffers, and the outer section continues to close over the middle section. It is essential the mast closes in this sequence.

To ensure the mast sections move in the correct sequence, and do not bind, ensure the wear screws are not over tightened as follows.

Ensure the gap between the overlapping mast section and the inner mast section is even on both sides. The distance is approximately 12mm, but may vary slightly due to manufacturing tolerances.

Loosen the wear screw lock nut and turn the screw until it just contacts the inner mast surface. Do not force the screw. Tighten the locknut using caution not to shear the screw thread. Raise and lower the mast to check it does not bind. (See picture).

In practice, it is far more likely that the screws may wear so an excessive gap between the mast section and the wear screw develops. This will be evident by free sideways movement of the platform. If this free movement is thought to be excessive, check the gap between the screw and the mast with a feeler gauge. The correct gap should be no more than 0.2mm, although the mast is serviceable with a gap up to 0.5mm.



Mast wear screw adjustment

MAINTENANCE FREQUENCY

The machine must have a thorough (LOLER) examination by a competent person at six monthly intervals.

MAINTENANCE FREQUENCY TABLE				
Item	Daily	Monthly	6 Months	12 Months
Batteries/Connections	●			
Battery Specific Gravity		●		
Oil Level	●			
Visual Inspection	●			
Spirit Level	●			
Castors	●			
Check Mast & Rollers		●		
Thorough Examination			●	
Change Hydraulic Oil				●
Motor Contactor Solenoids			●	

Thorough examination must include checking:

- All electrical connections, including battery.
- All hydraulic connections and cylinder for leaks.
- All connections are secure to powerpack.
- Handrails are undamaged and secure.
- Operation of gate latch.
- Platform tray condition.
- Mechanical condition of lifting structure and chassis.
- Swivel castor condition and security.
- Axle and wheels for condition and security.
- Condition and operation of spirit level.
- Condition of component and battery covers.
- Condition of all labelling.
- Carry out a full operation check and load test.
- Operation of motor contactors and that they have been replaced after every three years of service.

STORAGE

If the machine is to be taken out of operation for a period longer than one month, the following precautions should be taken.

Ideally, the battery charger should be switched on. The charger has an inbuilt maintenance mode, and will maintain the battery in good condition indefinitely, although obviously the electrolyte level must still be checked periodically. If this is not practical, then the charger should be switched on once a week for half an hour. This is especially important in cold conditions.

The hydraulic oil must be replaced (recommended after 3 months of non-use) as for the procedure in the Maintenance Procedures section.

If the storage period is for an undetermined period then it is advisable that the battery be removed and stored in a secure battery storage container. We would also advise that all external electrical and hydraulic connections be wax coated to prevent corrosion.

ELECTRICAL PARTS		Part No.
A	Pendant Controller c/w Cable	PTN-E-201
B	Emergency Stop/Battery Isolator	PTN-E-200
C	Battery Isolator Plastic Button	PTN-E-206
D	Battery Charger	PT-E-001
E	12V 105A Traction Battery	PT-E-002
F	110V Plug	PT-E-010
HYDRAULIC PARTS		Part No.
G	12V DC Powerpack Complete	PTN-H-251
H	Emergency Lowering Solenoid c/w Valve	PTN-H-255
*	Emergency Lowering Valve Cartridge	PTN-H-256
J	Steel Pipe Kit	PTN-H-260
*	Cylinder	PTN-H-276C
*	Cylinder Seal Kit	PTN-H-277

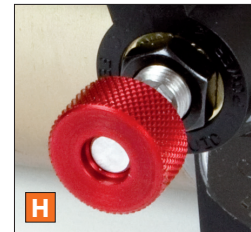
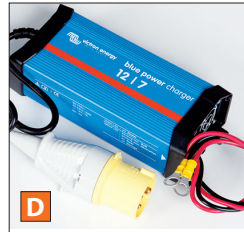
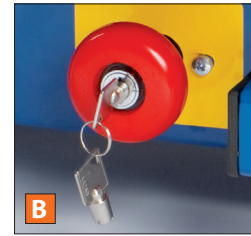

* Item not shown here

MECHANICAL & MISCELLANEOUS PARTS		Part No.
A	Wheel	PT-M-103
B	Swivel Castor	PT-M-102
C	Spirit Level	PT-M-106
D	Guardrails c/w Gate	PTN-M-350
E	Rubber Buffer	PT-M-126
F	Cover Securing Knob	PT-M-107
G	Tool Tray	PTN-M-303
H	Buffer Wheel	PTN-M-302
I	Decal Set 1	PTN-M-310
J	Decal Set 2	PTN-M-311
K	Decal Set 3	PTN-M-312
L	Keys (pair)	PTN-M-341
M	Gas Strut	PTN-M-340
N	Checkerplate Cover	PTN-M-320

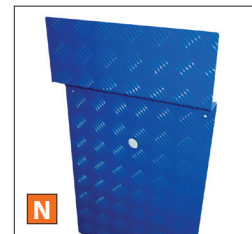
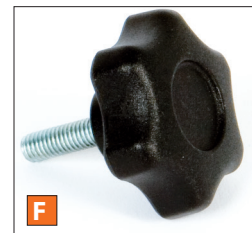
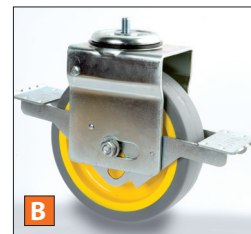

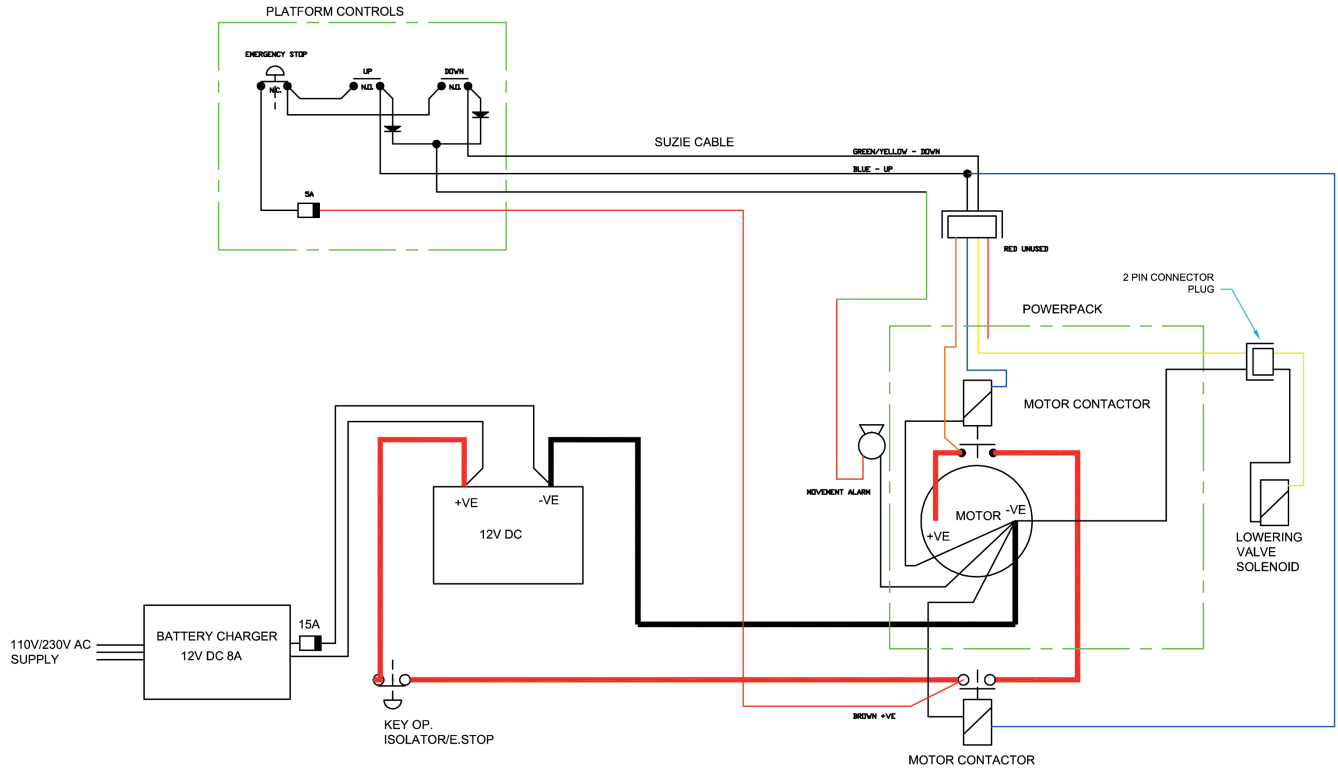

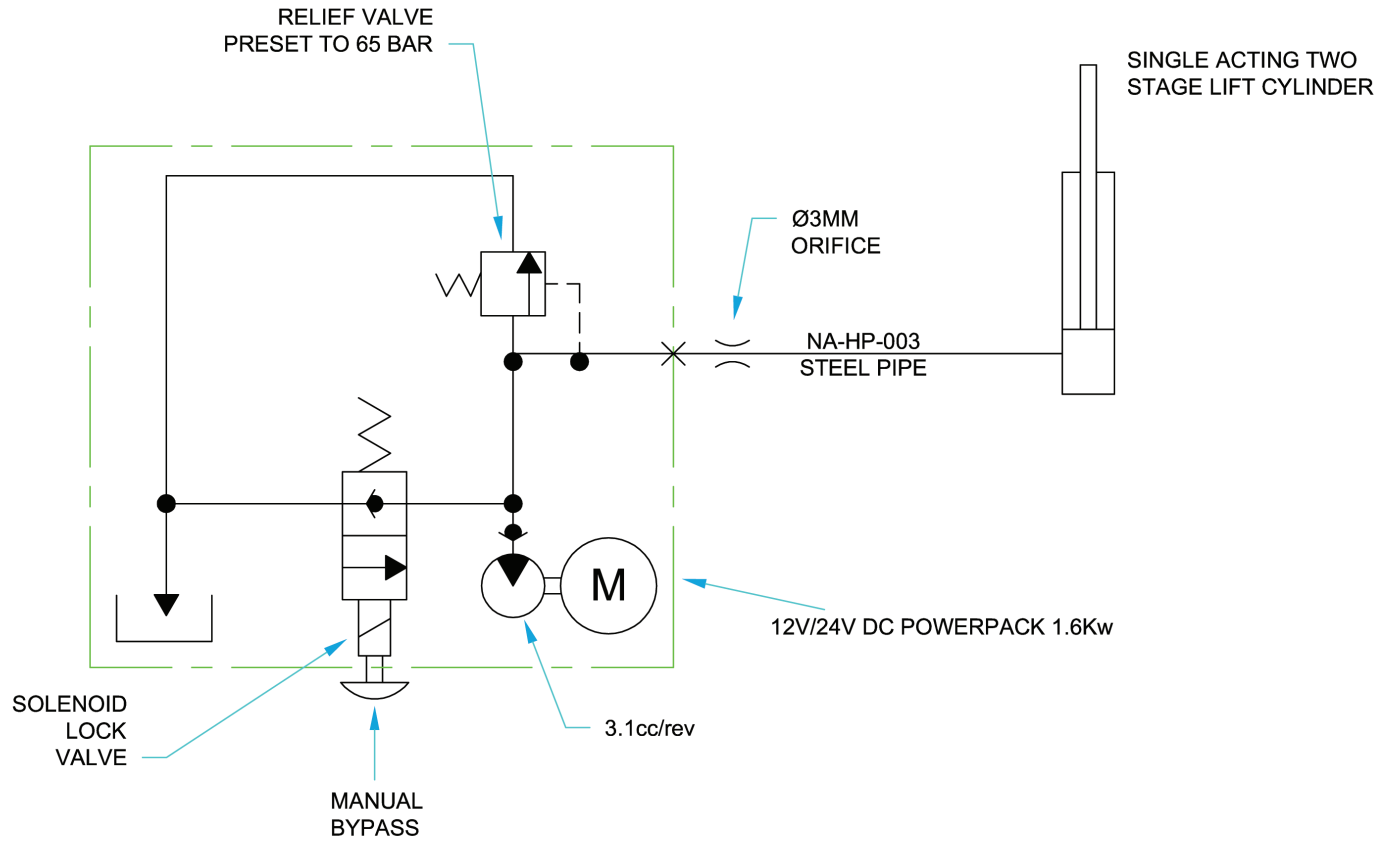

WARRANTY

Your Nano is covered by an 18 month parts/components warranty (excluding battery and battery charger). The Manufacturer Power Towers Ltd (The Company), undertakes to replace or repair, free of charge, any defective part/component, which the Company considers to be due to faulty workmanship or material within 18 months of the sale date, except for:

Defects arising from neglect, misuse or unauthorised modifications.

Damage caused by abuse, misuse, dropping or other similar damage caused by or as a result of failure to follow transportation, storage, installation, loading or operation instructions.

Alterations, additions or repairs carried out by persons other than the Manufacturer or their recognised distributors.

Transportation or shipment costs to and from the Manufacturer or their recognised agents, for repair or assessment against a warranty claim, on any Nano or component.

Materials and/or labour costs to renew, repair or replace components due to fair wear and tear.

Faults arising from the use of non-standard or additional parts, or any consequential damage or wear caused by the fitting or use of such parts.

Important

Warranty may, at the sole discretion of the Manufacturer, be voided if the scheduled service/inspections are not carried out in accordance with this manual.

The Manufacturer and/or their recognised agents, directors, employees or insurers will not be held liable for consequential or other damages, losses or expenses in connection with or by reason of or the inability to use the Nano for any purpose.

Modifications

If additional equipment or any third party work, modifications or alterations are to be carried out on the Nano which will involve any welding, drilling or any form of cutting or distortion of materials, full written approval must be obtained from the Manufacturer prior to the work being carried out.

