

**1. We advise that at least two persons should erect all towers for safety reasons**



2. Before erecting the tower ensure that site conditions are safe. Operatives must be competent and familiarise themselves with this assembly manual. Also make sure that sufficient equipment is available to erect the tower to the required height and that components are not damaged or incompatible. Check the tower breakdown for the quantities required.

3. Insert the adjustable legs and baseplates into the opening base ladder frames.



4. Place the two ladder frames on the staircase in the desired position approximately 1.5m apart, ensuring the baseplates are fully located on the steps of the staircase with the offset plate facing inwards towards the centre of the frame. Connect the two bottom rungs of the frames with a diagonal brace. The brace hooks should be located at the centre of the bottom rungs of the ladder frames to prevent them clashing with an erection platform when fitted. Level the frames by turning the adjustable leg nuts so that the bottom rung of the frame on the upper step is at the same level as the top rung of the frame on the lower step. The adjustable legs may be extended if necessary to achieve this.



5. Fit a trapdoor platform, with the trapdoor end located at the lower part of the stairs, to the bottom rung of the frame on the upper step and to the top rung of the ladder frame on the lower step. Ensure that the platform is level. There is a small bubble level on the underside of all Stairdeck platforms for ease of levelling. This platform is to be used for the temporarily safe erection of the tower and will be removed later for use further up the tower (see note 10 below)

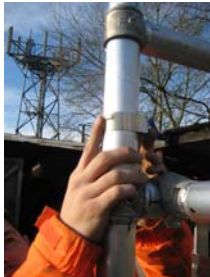

6. From the bottom of the staircase, fit a six rung upper frame to the top of ladder frame on the lower step. Lock the frames together using the interlock clips as shown on above left. Climb into the middle of the tower through the opening frame from the bottom of the staircase and climb partially through the platform and adopt the '3T' (Through the Trapdoor) position with your feet on rungs below the platform, as shown above. Fit four 1.5M horizontal guardrail braces to the verticals of the frames 0.5m and 1.0m above the platform to make a guard rail and then fit a diagonal brace between the bottom rung of the frame on the upper step and the upper frame located on the lower step. The brace should be placed on the flush side of the platform and will run in the opposite direction to the lower diagonal brace, forming a zig-zag pattern.



7. Now climb fully on to the platform, closing the trapdoor behind you and fit further six rung upper frames to either end of the tower. Fit a second trapdoor platform at the level of the top rung on the ladder frame on the upper step.

8. Climb partially through the second trapdoor platform and adopt the 3T position as in 6. Fit four 1.5M horizontal guardrail braces to the verticals of the frames 0.5m and 1.0m above the platform to make a guard rail and then fit a diagonal brace to continue the zig-zag bracing pattern. The brace should be placed on the flush side of the platform.



9. Now climb fully onto this platform and close the trapdoor behind you. Fit the four rung guard rail frame to the top of the frames on the upper step and the three rung guard rail frame to the top of the frames on the lower step. Lock the interlock clips to secure the frames together.



10. Descend the tower to the lowest platform and adopt the 3T position with your feet on the frame rungs below the trapdoor. Remove the four horizontal guard rail braces around this platform and then descend on to the staircase steps and remove the platform from the tower so that it and the braces can be reused and repositioned higher up the tower. Fit the trapdoor platform, which was removed from the bottom of the tower, to the fifth rung down from the top rung on the guard rail frames as shown on the left.

**ALWAYS ADOPT THE 3T POSITION WHEN FITTING OR REMOVING THE HORIZONTAL GUARDRAIL BRACES. DO NOT CLIMB ON TO ANY PLATFORM DURING THE ERECTION OR DISMANTLING OF THE TOWER UNTIL ALL FOUR HORIZONTAL GUARDRAIL BRACES ARE IN PLACE AROUND IT. ALWAYS CLIMB UP THE INSIDE OF THE TOWER.**



11. Climb partially onto this platform through the trapdoor and adopt the 3T position as described earlier and then fit four 1.5m horizontal guard rail braces at 0.5m and 1.0m above the platform as shown.

12. Fit the toeboard around the perimeter of the platform. The tower is now ready for use.

13. The instructions overleaf show the erection procedure for a tower erected to 4.3m platform height above the lowest step. To erect the tower to greater heights, repeat the instructions from 7 onwards adding extra six rung upper frames, erection platforms, guardrail frames and guardrail frames to reach the desired height. Always fit the four guardrail braces from the 3T position on a platform before climbing fully on to it. The tower should be dismantled in the reverse order.



14. The tower should be stabilised or braced against the building when being erected and used. In confined spaces the tower may well be trapped within a stairwell and require minimal further stabilisation. Typical examples of stabilisation methods are illustrated above which utilise specialist aluminium couplers and can also include the use of conventional alloy tower stabilisers if space and circumstances permit. Towers can also be tied in to stairwells using a variety of methods and fixings. If in doubt consult your supplier.

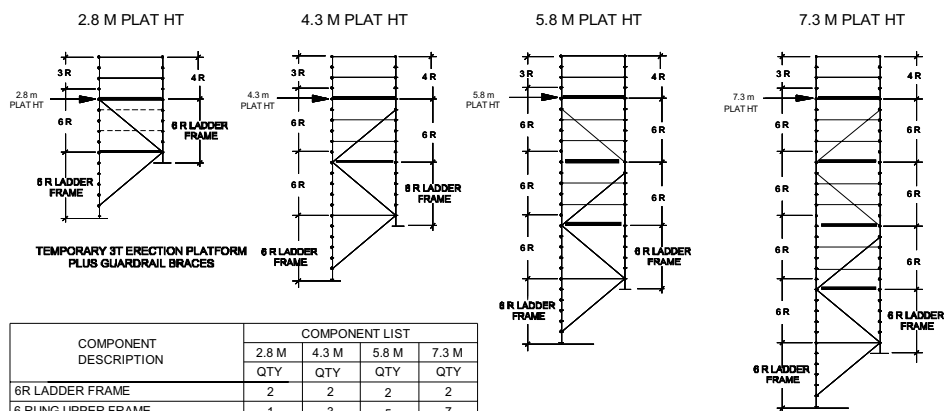

COMPONENT DESCRIPTION	COMPONENT LIST			
	2.8 M	4.3 M	5.8 M	7.3 M
6R LADDER FRAME	2	2	2	2
6 RUNG UPPER FRAME	1	3	5	7
4 RUNG GUARDFRAME	1	1	1	1
3 RUNG GUARDFRAME	1	1	1	1
1.9 M DIAGONAL BRACE	2	3	4	5
1.5 M HORIZONTAL BRACE	5	9	13	17
1.5 M HATCHDOOR PLATFORM	1	2	3	4
TOEBOARD SET	1	1	1	1
ADJUSTABLE LEGS & BASE PLATES	4	4	4	4

STABILISERS AND TYING IN EQUIPMENT NOT INCLUDED IN ABOVE

**3T STAIRDECK TOWER SET-UP**

Manufactured under an ISO9001:2008 Quality System by:-

Interlink Alloy Systems Limited  
 Tel: 01992 716509 Fax: 01992 652500  
 E-mail: sales@interlinkalloy.co.uk  
 Web: www.interlinkalloy.co.uk  
 For further information or assistance, please contact us.  
 Complies fully with the Working at Height Regulations 2005

**SAFE WORKING LOAD**

The safe working load on any platform will be 275kg evenly distributed over the whole platform area.  
 The Safe Working Load on the tower is 750kg, less the self weight of the tower

# Interlink Alloy Systems Limited

## 3T STAIRDECK ASSEMBLY GUIDE

### TYPICAL 2.8 M SET-UP

( showing temporary 3T erection platform and braces in position )

